

**Jean Birmingham Council  
Chambers, City Hall**  
401 South Alamo  
Marshall, TX 75670  
903-935-4421



**Members**  
Amy Ware, District 4 - Mayor  
Risa Jordan-Anderson, District 1  
Leo Morris, District 2  
Dathaniel Campbell, District 3  
Reba Godfrey, District 5  
Amanda Abraham, District 6  
Micah Fenton, District 7

**PLEASE SILENCE ALL DEVICES  
REGULAR CITY COUNCIL MEETING**  
September 25, 2025  
6:00 PM

**1. Call to Order and Roll Call**

**2. Invocation and Pledges**

**3. Presentations & Proclamations**

- A. Presentation of a proclamation declaring the month of October 2025 as "Domestic Violence Awareness Month" in the City of Marshall. (Mayor Ware)
- B. Presentation of the Employee of the 3rd Quarter 2025. (Employee Engagement Committee)
- C. Presentation of a proclamation designating September as Boogie Woogie Marshall Month and proclaiming September 26 and 27, 2025 as "Huddie 'Lead Belly' Ledbetter Day."
- D. Recognition of the September Yard of the Month winners.

**4. Citizen Comments**

Texas Government Code, Sec. 551.007 requires that a governmental body must allow each member of the public who desires to address the body regarding an item on the agenda the opportunity to do so before or during the body's consideration of the item. The "Citizens Comments" portion of the meeting meets the requirements of this law and is the public's opportunity to speak on any item on the agenda. Those who wish to speak are requested to fill out a public comment form and will have three (3) minutes to speak unless additional time has been requested.

**5. Items to be Withdrawn From Consent Agenda**

**6. Consent Agenda**

The items on the Consent Agenda require little or no deliberation by the Council. Approval of the Consent Agenda authorizes the City Manager or his designee to proceed with conclusion of each in accordance with staff recommendations, a copy of which is filed with the minutes of the meeting. A Councilmember may remove items from the Consent Agenda by making such request prior to a motion and vote on the Consent Agenda.

- A. Consider approval of the minutes from the August 18, 2025 Special-Called Work Session meeting. (City Secretary)
- B. Consider approval of the minutes from the August 28, 2025, Special-Called Work Session meeting. (City Secretary)

**7. Consideration of Items Withdrawn From the Consent Agenda**

## 8. Public Hearing & Ordinance

- A. Conduct 2<sup>nd</sup> Public Hearing on the Proposed Budget for Fiscal Year 2026 and Consider approval of an ordinance to adopt the annual budget of the City of Marshall, Texas for the 2026 fiscal year.
- B. Conduct a public hearing and consider approval of an ordinance affixing and levying 2025 ad valorem taxes for the use and support of the municipal government of the City of Marshall for the 2026 fiscal year at a rate of \$0.5815183 per \$100 of property value, *which is effectively a 9.32 percent increase in the tax rate. The tax rate of \$0.5815183 will raise more taxes for maintenance and operations than last year's tax rate.* (Asst. City Manager)
- C. **O-25-XX** Conduct a public hearing and consider approval of an ordinance regarding a rezoning request for 1801 University Ave from R-2 (Single Family Detached) to R-6 (Duplex Triplex Quadraplex) (**P&Z Item ZBA-25-04**). (Development Services)
- D. **O-25-XX** Conduct a public hearing and consider approval of an ordinance regarding a rezoning request for 3001 N East End Blvd from A-E (Agriculture & Estate) to C-3 (General Business) for Commercial Uses. (**P&Z Item ZBA-25-09**). (Development Services)

## 9. Action Items for City Council Consideration

- A. Consider approval for the purchase and installation of a new drive unit from RBIS, LLC. for the Wastewater Treatment Plant's Primary Clarifier #1. \$54,695.00
- B. Consider approval to award a bid for electrical and plumbing work at the City Arena to LFA4 Enterprises, LLC (TIPS Contract 24010402), not to exceed \$61,136. (Facilities)

## 10. Discussion and Reports for City Council Consideration and Direction

- A. Discussion regarding the need to establish a Charter Review Committee. (Councilmembers Godfrey, Jordan – Anderson & Morris)

## 11. Adjournment

Posted: September 19, 2025

5:10 PM

N. Smith

This meeting will be conducted in accordance with the Americans with Disabilities Act. Requests for sign interpretive services will be available with at least 72-hour notice prior to the meeting. To make arrangements for these services, please call the City Secretary's Office at 903-935-4446.

# TAXPAYER IMPACT STATEMENT FOR THE CITY OF MARSHALL

Pursuant to §551.043 Texas Government Code

PROPOSED TAX RATE	<u>\$0.58151830 per \$100</u>
NO-NEW-REVENUE TAX RATE	<u>\$0.53189530 per \$100</u>
VOTER-APPROVAL TAX RATE	<u>\$0.58151830 per \$100</u>
2025 MEDIAN* TAXABLE HOMESTEAD VALUE	<u>\$113,080</u>
2025 EST OF TAX ON MEDIAN HOMESTEAD @ PROPOSED RATE	<u>\$657.58</u>
2025 EST OF TAX ON MEDIAN HOMESTEAD @ NO-NEW-REVENUE RATE	<u>\$601.47</u>

The Texas Legislature has amended §551.043 of the Texas Government Code to require a Taxpayer Impact Statement to be included with a governing body's notice of meeting to adopt budgets and tax rate.

The tax rate proposed this year by the City Council of the CITY OF MARSHALL is \$0.58151830/ \$100 of value.

The median taxable value of a homesteaded property in the CITY OF MARSHALL for 2025 is \$113,080.

The proposed tax rate would result in an estimated tax on the median homestead of \$657.58.

If the City Council of the CITY OF MARSHALL adopted a tax rate equal to this year's no-new-revenue rate of \$0.53189530/ \$100 of value, the tax on the median homestead property for 2025 would be \$601.47.

*\*The Texas Legislature has required the use of the median homestead value for this statement. The median taxable value will differ from the average taxable value contained in other statutory tax transparency notices.*



TO: City Council  
DATE: September 25, 2025  
ITEM #: 3.A  
SUBJECT: Presentation of a proclamation declaring the month of October 2025 as "Domestic Violence Awareness Month" in the City of Marshall. (Mayor Ware)

**Recommendation for Action:**

**Executive Summary:**

**Focus Area(s):**

**Budget Cost:**

**Staff Contact:**

- Attachments:**
1. Domestic Violence Awareness Month 2025
  2. TooCloseToHome-flyer

# PROCLAMATION



## *Domestic Violence Awareness Month*

**WHEREAS**, the crime of domestic violence violates an individual's privacy and dignity, security and humanity, due to systematic use of physical, emotional, sexual, psychological and economic control and/or abuse, including abuse to children and the elderly; and

**WHEREAS**, the problems of domestic violence are not confined to any group or groups of people, but cut across all economic, racial and societal barriers, and are supported by societal indifferences; and

**WHEREAS**, the impact of domestic violence is wide ranging, directly affecting individuals and society as a whole, here in the community, throughout the United States, and the world; and

**WHEREAS**, the Women's Center of East Texas is focused on ending violence by providing shelter, support, and safety to victims of domestic violence; and

**WHEREAS**, survivors of domestic violence themselves have been at the forefront of efforts to bring peace and equality to the home,

**NOW, THEREFORE**, the City Council of Marshall, Texas, in recognition of the important work done by domestic violence programs, does hereby proclaim the month of October 2025 to be "*Domestic Violence Awareness Month*" and urges all citizens to actively work toward eradicating domestic violence, improving survivor safety and holding perpetrators of domestic abuse accountable for their actions against individual survivors and our society as a whole.

---

Amy Ware, Mayor  
Marshall City Council



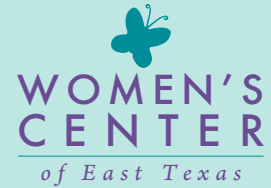

# TOO CLOSE TO HOME

UNITING AGAINST VIOLENCE

**OCTOBER 14, 2025**

**8:00 a.m. - 5:00 p.m.**

**Maude Cobb Convention Center  
100 Grand Blvd + Longview, TX**

**FEATURING**

- + **Nationally renowned speakers**
- + **Continuing education hours**
- + **Food trucks and more!**

**Free  
Registration**



**Scan Here!**

Or Visit [TooCloseToHomeETX.com](http://TooCloseToHomeETX.com)

**WOMEN'S CENTER OF EAST TEXAS  
THE MARTIN HOUSE CAC  
BUCKNER CHILDREN & FAMILY SERVICES  
GREATER LONGVIEW UNITED WAY  
ROTARY CLUB OF LONGVIEW  
ZONTA CLUB OF LONGVIEW**

[TooCloseToHomeETX.com](http://TooCloseToHomeETX.com)



TO: City Council  
DATE: September 25, 2025  
ITEM #: 3.B  
SUBJECT: Presentation of the Employee of the 3rd Quarter 2025. (Employee Engagement Committee)

**Recommendation for Action:**

**Executive Summary:**

The Employee Engagement Committee is a dedicated assembly of employees who have voluntarily united with the common goal of orchestrating and executing activities aimed at engaging and motivating their fellow colleagues. Their primary mission is to cultivate a positive and productive workplace culture while actively enhancing the employer-employee relationship. Among the initiatives employed is the recognition of outstanding contributions through the Employee of the Month program. The committee diligently reviews nominations, carefully deliberates, and collectively decides on the deserving individual to receive this esteemed acknowledgment.

**Focus Area(s):**

**Budget Cost:**

**Staff Contact:** Christol Hall, HR Director

**Attachments:** None



TO: City Council  
DATE: September 25, 2025  
ITEM #: 3.C  
SUBJECT: Presentation of a proclamation designating September as Boogie Woogie Marshall Month and proclaiming September 26 and 27, 2025 as "Huddie 'Lead Belly' Ledbetter Day."

**Recommendation for Action:**

**Executive Summary:** In recognition of the achievements of Boogie Woogie Marshall, present a proclamation designating September 2025 as Boogie Woogie Marshall Month and proclaiming September 26 and 27, 2025 as "Huddie 'Lead Belly' Ledbetter Day."

**Focus Area(s):**

**Budget Cost:**

**Staff Contact:**

**Attachments:** 1. Boogie Woogie Month 2025

# PROCLAMATION



**Whereas**, the City of Marshall, Texas and its community hold a deep appreciation for music and proudly recognize that Boogie Woogie originated in the Piney Woods of East Texas, specifically the Marshall area, in the 1870's; and

**Whereas**, in honor of this rich musical heritage, the City of Marshall proudly adopted the designation of the "Birthplace of Boogie Woogie; and

**Whereas**, Boogie Woogie Marshall has made continued to preserve and celebrate Boogie Woogie music and history, with critically acclaimed events, opening of the Boogie Woogie Museum, and working with students of Wiley University, Marshall High School, and Marshall Fine Arts Academy; and

**Whereas**, Boogie Woogie Marshall has announced that Boogie Woogie 2025 will celebrate Boogie Woogie and also include a Tribute to Huddie Ledbetter, known throughout the world as "Lead Belly;" and

**Whereas**, Marshall has a special connection to Lead Belly – in September 1935, Lead Belly met John Lomax, a pioneering musicologist and folklorist, at the Hotel Marshall, also called The Marshall, and based on that meeting Lead Belly and Lomax went on the road, which resulted in Lead Belly being introduced to audiences in New York and around the world; and

**Whereas**, Lead Belly has influenced countless musicians since his passing in 1949, and he continues to do so to this day; George Harrison of the Beatles had this to say: "no Lead Belly, no Beatles;" and

**Whereas**, the City of Marshall looks forward to welcoming Lead Belly descendants from near and far and opening of the Lead Belly Room at the Boogie Woogie Museum;

**NOW, THEREFORE**, in recognition of the achievements of Huddie Ledbetter and Boogie Woogie Marshall, be it resolved that the City of Marshall, Texas, in accordance with the foregoing findings, hereby officially proclaims September 26 and 27, 2025 as "Huddie 'Lead Belly' Ledbetter Day."

**IN WITNESS, WHEREOF** we hereunto set our hands and cause the Seal of Marshall, Texas to be herein affixed.

\_\_\_\_\_  
Amy Ware, Mayor  
City of Marshall, Texas





TO: City Council  
DATE: September 25, 2025  
ITEM #: 3.D  
SUBJECT: Recognition of the September Yard of the Month winners.

**Recommendation for Action:** Recognize recipients of Keep Marshall Beautiful's September 2025 Yard of the Month award.

**Executive Summary:** Keep Marshall Beautiful selected a residential and commercial property for the September 2025 Yard of the Month award. Representatives from the Keep Marshall Board will present both winners with a \$50 gift card from Lowe's.

**Residential Winner:**

Charles & Sandra Jo Bledsoe (401 W Emory)

**Commercial Winner:**

Lorena's Hair Studio (902 E Pinecrest)

**Focus Area(s):** This item aligns with the following council adopted focus area(s): Improving Community Appearance

**Budget Cost:**

**Staff Contact:** Alex Agnor, Assistant City Manager/Director of Economic Development & Strategic Initiatives

**Attachments:** None



TO: City Council  
DATE: September 25, 2025  
ITEM #: 6.A  
SUBJECT: Consider approval of the minutes from the August 18, 2025 Special-Called Work Session meeting.  
(City Secretary)

**Recommendation for Action:** Consider approval of the minutes from the August 18, 2025 Special-Called Work Session meeting.

**Executive Summary:** Minutes from the August 18, 2025 Special-Called Work Session.

**Focus Area(s):** Improving Communication

**Budget Cost:** N/A

**Staff Contact:** Nikki Smith, City Secretary

**Attachments:** 1. 8-18-25 minutes

**Marshall Convention Center**  
2501 East End Blvd South  
Marshall, TX 75672  
903-935-4421



**Members**  
Amy Ware, District 4 - Mayor  
Risa Jordan-Anderson, District 1  
Leo Morris, District 2  
Dathaniel Campbell, District 3  
Reba Godfrey, District 5  
Amanda Abraham, District 6  
Micah Fenton, District 7

**MINUTES**  
**PLEASE SILENCE ALL DEVICES**  
**SPECIAL-CALLED CITY COUNCIL WORK SESSION**  
**August 18, 2025**  
**4:15 PM**

**1. Call to Order and Roll Call**

Mayor Amy Ware called the Special-Called Work Session meeting to order in the Marshall Convention Center at 4:31 PM.

**PRESENT:**

**Mayor and Council Members:**

Mayor Amy Ware  
Councilmember Leo Morris  
Councilmember Reba Godfrey  
Councilmember Amanda Abraham  
Councilmember Micah Fenton  
Councilmember Dathaniel Campbell  
Councilmember Risa Jordan-Anderson

**2. Citizen Comments**

Texas Government Code, Sec. 551.007 requires that a governmental body must allow each member of the public who desires to address the body regarding an item on the agenda the opportunity to do so before or during the body's consideration of the item. The "Citizens Comments" portion of the meeting meets the requirements of this law and is the public's opportunity to speak on any item on the agenda. Those who wish to speak are requested to fill out a public comment form and will have three (3) minutes to speak unless additional time has been requested.

There were no citizen comments.

**3. Discussion and Report for City Council Consideration and Direction**

A. Discussion regarding establishing Council Committees: a. Information Technology Committee (IT Committee) and b. Policy Development Committee. (City Manager) Melissa Vossmer, City Manager, stated this item was a late addition to the agenda but is an opportunity for staff to take advantage of the Council's expertise and interest in various areas. Two of the areas were identified as an IT Committee and an Advisory Council Committee for Policy Development. There are already two council members

willing to volunteer on the IT Committee. What the committees will do, how they are to be structured and what the missions will be, have not been identified at this time. The first step is to see if the council wants to create committees, then discussions will be had regarding scope, projects, how to meet, how to inform the Council and create a work plan for the upcoming months.

Councilmember Campbell stated there are some challenges to how businesses develop in Marshall. The City has a policy, but it's not a written policy. Recommended staff to write down the rules, so things can be consistent and all be equal, with no deviation.

Melissa Vossmer stated ordinances aren't policy, but they are used in guiding staff. Work is being done on the purchasing policy and implementation. There are other areas of interest that it is time to develop our own policies for.

Mayor Ware asked if there were volunteers for the IT Committee, which Councilmembers Abraham and Morris volunteered for.

Mayor Ware stated she would be willing to volunteer on a policy committee. Councilmembers Godfrey and Campbell also volunteered to be on the policy committee.

Councilmember Jordan-Anderson asked if the council would take the lead or staff on the committees. Melissa Vossmer said they would be directed by the council and staff would help.

B. Presentation of City of Marshall Water & Wastewater Rate Study 5-Year Plan.  
(Finance)

Kristina Hamilton, Interim Finance Director, introduced Chris Ekrut, partner and CFO of New Gen Strategies and Solutions, who presented information regarding the City of Marshall Water and Wastewater Rate Study.

Chris Ekrut discussed business fundamentals of revenue sufficiency, reserves and reinvestment. Chris Ekrut stated the water and wastewater infrastructure was evaluated and for many years no significant investment was made in capital improvement. Debt was issued in 2024 to replace or repair the infrastructure and a capital improvement plan has been created with projects totaling over \$70 million.

Chris Ekrut stated three scenarios for the rate design have been created. Each scenario includes \$1 million for maintenance, and rate increases will be smoothed out, where possible, to align with debt issuance. No changes to the rate structure are being recommended at this time. Customers who live outside the city will not have rates increase until the multiplier is at 1.2. Chris Ekrut provided an affordability analysis review, community rate comparison, and regional bill comparison.

An overview of the three scenarios for the rate design was provided, which include CIP funding over the next five years and the customer impact. The three scenarios are for:

1. \$56 million
2. \$42 million

### 3. \$28 million

Councilmember Abraham asked about the non-city residents who get water. It was explained that since they don't elect the council, they have no voice and would have to go to the state and if they go to the state, the state can then make the rate case.

Councilmember Jordan-Anderson asked about the calculation of the different average incomes and the data used. The calculation used is the household income average, which is used by the EPA.

Kristina Hamilton stated the projects are being presented in priority order and can be covered by any of the scenarios, except the last \$250,000 project.

Melissa Vossmer stated the original projects were reviewed and reworked to determine what should be included in the top five, ten, and 20 projects to be included in the various funding packages and to address areas of council concern and where we currently have EPA or TCEQ issues.

Deck Shaver, Interim Public Works Director, provided detailed information about the various utility projects for the water and sewer system, which total approximately \$28,250,000.

Councilmember Jordan-Anderson asked for more information about the undersized watermains.

Melissa Vossmer stated the proposed plan begins to address the issue but does not cover the entire city.

Kristina Hamilton stated the cost estimate for the watermain project was \$38 million, but it is being proposed to address the project in smaller portions starting with two \$5 million increments at this time and coming back to council for future replacements.

Melissa Vossmer stated the original plan was looking at 30–40 years to replace the water lines. The plan is now looking at 15–20 years with consideration of the city's capacity to do the work.

Councilmember Jordan-Anderson asked about the planning of where to start the project and how to go about replacing the streets or watermains first.

Deck Shaver stated his department would be working with the Council and staff to create a plan.

Melissa Vossmer stated work will be done to move the lines from beneath the streets into the City's right-of-ways.

Councilmember Campbell asked if the number one concern is to become compliant for safety reasons and asked what items had to be fixed for compliance, which was said would be the trickling filter and bio tower.

Councilmember Godfrey stated that for us to get in compliance with EPA and TCEQ it would cost \$11 million.

Melissa Vossmer stated efforts will be made to make improvements where possible and get in compliance.

Councilmember Abraham asked how long it would take if \$5 million was set aside for watermains, which was determined would be approximately 1–2 years. Councilmember Abraham also asked when considering whether a watermain is to be repaired, replaced or moved, if it won't be done for years, to go ahead and fix the street if the street is on the street improvement program list.

Mayor Ware asked about the \$1 million for the 30-year-old hydrants and non-working hydrants, if that would cover all non-working hydrants, which it was said it should get close.

Councilmember Abraham expressed her appreciation of bringing a priority list to make it easier to understand and determine where to start.

Councilmember Morris asked if there is a roster showing where fire hydrants have been replaced, and the location of ones that will be replaced? The Fire Department and Public Works Department have worked together to map the locations. The streets that are not serviced by the correct number of hydrants are being reviewed and locations for hydrant replacement and installation of new hydrants are under review.

Councilmember Jordan-Anderson asked about the projection to replace the hydrants, which was stated to be in the plan to replace hydrants that are not operational and/or 30 years old. Councilmember Jordan-Anderson asked where the Fire Department gets water from if the hydrant is not working, and it was stated the Fire Department has plans in place for such occurrences.

Councilmember Abraham stated an employee was tasked with replacing the hydrants, but the position became vacant, and the Fire Department took over the task.

Deck Shaver stated replacement of the primary and secondary clarifiers is a priority, as well as installing automatic control valves at elevated water storage tanks.

Melissa Vossmer asked if the Council would like staff to go through the remaining projects with less chance of getting funding this year. Mayor Ware said it would be helpful to go through the remaining items.

Deck Shaver discussed other projects that need to be addressed, including interceptors, lift stations, plant expansion, waterline repairs, sludge fan press and installation of a second grit chamber.

Councilmember Jordan-Anderson asked about upgrades to the lift station and how many there are in the City. There are a total of 23 with different priority levels based on the results of engineering evaluations. Councilmember Jordan-Anderson asked about the location of lift stations 14 & 15, which are on Fisher Drive. It was stated that one of them is not functioning but is still on insurance. This will be reviewed to see if it needs

to be removed from the insurance.

Kristina Hamilton asked for direction regarding the scenarios, which will be brought back at a future meeting as an ordinance for rates to go into effect January 1, 2026.

Melissa Vossmer stated she would like this information to be brought to council to incorporate the information into the budget. Mayor Ware stated she would like the information to be made available for the public to have time to review it and provide input before the council gives direction.

Councilmember Campbell suggested including the year when a project was initially completed in the budget. Melissa Vossmer said the age of infrastructure can be included and what is being done to move forward.

Councilmember Campbell asked what would happen if compliance was not obtained in 2026, in which Deck Shaver explained that TCEQ and the EPA try to work with cities on a case-by-case basis to ensure they are making improvements. Councilmember Campbell asked about the possibility of being fined if we don't get the items addressed, and it was explained that if the city is fined those funds are used to reinvest in the infrastructure.

Kristina Hamilton stated that although council is being asked to look at and adopt a rate study that will provide funding for debt-related projects in the future, staff will have to bring back the list each time they issue debt. The debt issuance is anticipated to be every other year to give time for project completion and financial capacity.

- C. Discussion regarding the FY25 Street Improvement Program. (Council)  
Stan Hayes, Hayes Engineering, provided historical street improvement project information, and details regarding the 2024 contract with Rayford Truck and Tractor. The street selection process was composed of council suggestions and citizen complaints. A list and map were created based on these recommendations for street improvements as well as the PCI scores and onsite reviews.

Councilmember Abraham asked about the percentage of streets spread out per district.

Councilmember Fenton stated a patch of 15 feet should not be considered a street replacement.

Councilmember Jordan-Anderson stated she has a list of streets in her district, and asked if she could turn them in now or at a later time.

Councilmember Abraham stated the new PCI numbers have been received.

Councilmember Fenton said the selection should reflect the flow of traffic and not just the number of houses on a street.

Stan Hayes stated there are many different ways to create a selection process and suggested possibly splitting the funding between local, collector, and high traffic/through streets.

Melissa Vossmer asked council to provide specifically what they are looking for in the selection as the materials have been bid and staff needs direction on how to proceed.

Councilmember Jordan-Anderson stated she reviewed every street in her district and needs to submit the information for the streets that need to be included in the list.

Stan Hayes suggested selecting the streets earlier next year, and Melissa Vossmer stated she would like to start the dialogue in January and start the project in late February or mid-March as the program for FY26 will be larger.

Councilmember Fenton asked if the same index was going to continue to be used, and feels that streets keep being pulled on and off of the list. Stan Hayes said something needs to be done, and we can't use just PCI as the determining factor. Stan Hayes suggested again the possibility of splitting the funds that are available.

Melissa Vossmer stated different treatment options are being reviewed for the upcoming project year which should help afford additional street repairs next year.

Councilmember Godfrey stated that Stan Hayes has given his recommendation and, as he is an expert on the subject, she asked why his list wasn't accepted.

Councilmember Morris street improvement is a big thing; repairs are being done on streets that didn't meet the criteria for repair. Work done should be fair and equitable.

Councilmember Abraham stated there should be separate funds for different types of repairs.

Stan Hayes stated he could show pictures of the types of streets and what could be done to sustain them for another 10 years without a complete reconstruction.

Melissa Vossmer stated we need to gear up a maintenance program and update the ordinances that govern how businesses do work on the city roadways to require the city to inspect and approve the work.

Councilmember Campbell said there would not be a perfect plan, but we have to have something, and he would like that plan to include a better maintenance program.

Councilmember Jordan-Anderson stated she looked at the recommended list and counted the number of streets in District One, and it did not seem to be fair as there are 21 in District One and 10 in the other districts. She asked to have the list revisited.

Councilmember Abraham said this year a new approach has been taken to review the streets and stated she appreciates the work that has been put into the creation of the street list.

Mayor Ware said the PCI is done so it won't delay the progress for 2026, which should be able to be done at a faster rate.

Melissa Vossmer stated staff needs to bring something for approval and asked if council is ready to give direction or what additional information is needed to get the

streets in a more desirable condition.

Mayor Ware asked the council members if they wanted to make any changes to the streets in their Districts that are on the list.

Councilmember Campbell stated if the street on the list is short, or only has a small portion remaining, to go ahead and finish it.

Councilmember Abraham stated when the replacement gets to the intersection and stops, it creates bumps. She suggested having a contingency buffer to cover going through the intersection, which may require one less street on the list to have some money available.

Councilmember Campbell asked if the streets with seams have a better life expectancy, which Stan Hayes explained the process of building the streets for drainage and smooth intersections.

Councilmember Godfrey stated Magnolia Street was missing and did not get a PCI score. Stan Hayes explained that there are streets that are not included in the list because of not having houses on the streets that front them.

Melissa Vossmer stated she would have the item placed on the agenda for the August 28th meeting for action.

D. Capital Improvement Plan: Project Planning, Funding Strategies, and Timeline Discussion. (Finance)

Krisitna Hamilton explained that a Capital Improvement Plan (CIP) is a strategic planning document that outlines the major capital project for a ten-year period. It provides a roadmap for the City's maintenance of and improvements to infrastructure.

Melissa Vossmer stated lessons are always learned when creating CIPs.

Kristina Hamilton stated the 2023 CIP was a ten-year program, and we are now looking at a five-year program with debt issuance based on capacity, and other key considerations including community needs & priorities, financial capacity, project costs & timing, maintenance & lifecycle planning, regulatory compliance, interdepartmental coordination, economic development impact, public input & transparency, flexibility & contingency planning. The 2026-2027 project list for the debt issuance of \$10.175 million (\$7,775,000 Ad Valorem (I&S Tax), \$2,400,000 Water & Waste Water Utility) includes: city facility improvements including a needs assessment and parking lot upgrades; Airport Park improvements including a concession stand, restrooms and sidewalks; Citywide playgrounds; IT infrastructure upgrades; an ERP System; Police Department improvements including an Emergency Command Center, training and evidence rooms and a generator; Fire Department improvements including Fire Station 2 replacement and relocation, fire apparatus and a generator; and annual street improvements.

Councilmember Abraham asked about the golf course restrooms and clubhouse, asking if those were the only updates planned, and stated she would like to see course upgrades added to the list.

Councilmember Godfrey asked about generators and if these were in addition to the ones purchased by the Hazmat Mitigation Grant, which they are. Councilmember Godfrey asked about enhancements to Citywide playground equipment, which will be further out than the 2026/2027 program year, and a roof replacement for the Public Works building.

Randy Pritchard, Support Services Director, stated the Public Works building is an engineered steel building and replacing the roof and re-skinning it would make it more useful.

Councilmember Campbell stated it looked like some of the items are also plans on the rate study list. It was stated that yes, they are on both lists, they are placed on the list as part of it to cover a portion of the project if it is not done with TWDB.

Deck Shaver explained there are two treatment lines running parallel with each other and the goal is to keep at least one side moving.

Councilmember Campbell asked about the cost presented on the rate study versus the cost listed on the CIP. Kristina Hamilton explained the CIP amount is being backed into, and if the TWDB project is approved, more items on the CIP list will be able to be addressed.

Melissa Vossmer stated we will put the projects on the next agenda to talk in more detail, so the council is comfortable with the project selection.

Kristina Hamilton stated we have a timeline to address the violations from TCEQ.

Mayor Ware mentioned repairs and updates needed, including IT needs; Parks & Recreation community centers need repairs, park improvements, golf building upgrades and course work; the library parking lot; and requested more information on the fire station relocation. The fire station is anticipated to be relocated to the southern portion of the Hwy 59 corridor.

Councilmember Fenton mentioned the City Arena parking lot needs repairs.

Councilmember Abraham asked where the fire station was being relocated. Assistant Fire Chief Randall Jeans stated station 2 would move from Indian Springs to Hwy 80 to cover more of the North and East areas of town and station 4 would be relocated to an area around Cox Road and Hwy 59. Assistant Chief Jeans stated Chief Rainwater has a map that indicates the planned relocation would allow the firefighters' response time to be within four (4) minutes for 90% of the city. Assistant Chief Jeans stated station 2 is the biggest need and the fire department is also looking into building a training facility.

E. Fiscal Year 2026 Budget Presentation. (City Manager)

Melissa Vossmer provided an overview of the budget and a road map for more and better planning for the future. Melissa Vossmer stated the city's mission, vision and core values, explained the updated organization chart, and the focus areas that were developed from the Council Work Sessions (Improve all Infrastructure, Invest in our

Workforce, Improve Communications with the Community, Improve Communications with and among City Employees, Improve Customer Service and Improve Community Appearance). Melissa Vossmer explained how these items relate to and are addressed in the budget. Melissa Vossmer stated there is no reduction in service, no new positions, the budget is being "right-sized", and the total FY26 annual fiscal budget is \$50,939,330.

The next steps in the process are to have budget discussions to modify the proposed budget, hold two (2) public hearings on September 11th and 25th, and approve the budget.

Councilmember Morris made an observation that we need to celebrate our successes, and he would like to see something posted at worksites stating "Your Tax Dollars at Work" to show the public what work is being done within the City.

Mayor Ware thanked the Council, staff and consultants for their hard work.

**4. Adjournment**

**Councilmember Abraham made a motion to adjourn. Councilmember Campbell seconded the motion, which passed by a vote of 7:0.**

APPROVED:

---

Mayor of the City Council  
of the City of Marshall, Texas

ATTEST:

---

City Secretary



TO: City Council  
DATE: September 25, 2025  
ITEM #: 6.B  
SUBJECT: Consider approval of the minutes from the August 28, 2025, Special-Called Work Session meeting. (City Secretary)

**Recommendation for Action:** Consider approval of the minutes from the August 28, 2025, Special-Called Council meeting.

**Executive Summary:** Minutes from the August 28, 2025, Special-Called Council meeting.

**Focus Area(s):** Improving Communication

**Budget Cost:** N/A

**Staff Contact:** Nikki Smith, City Secretary

**Attachments:** 1. 8-28-25 work session minutes

2nd Floor Conference  
Room, City Hall  
401 South Alamo  
Marshall, TX 75671  
903-935-4421



**Members**  
Amy Ware, District 4 - Mayor  
Risa Jordan-Anderson, District 1  
Leo Morris, District 2  
Dathaniel Campbell, District 3  
Reba Godfrey, District 5  
Amanda Abraham, District 6  
Micah Fenton, District 7

**MINUTES**  
**PLEASE SILENCE ALL DEVICES**  
**SPECIAL-CALLED CITY COUNCIL MEETING**  
**August 28, 2025**  
**4:45 PM**

**1. Call to Order and Roll Call**

Mayor Amy Ware called the Regular meeting to order in the Council Chambers, City Hall at 4:48 PM.

**PRESENT:**

**Mayor and Council Members:**

Mayor Amy Ware  
Councilmember Leo Morris  
Councilmember Reba Godfrey  
Councilmember Amanda Abraham  
Councilmember Micah Fenton  
Councilmember Dathaniel Campbell  
Councilmember Risa Jordan-Anderson

**ADMINISTRATIVE STAFF PRESENT:**

Melissa Vossmer, City Manager  
Christol Hall, HR/Civil Service Director  
Julie Richards, Interim Budget Manager  
Randy Pritchard, Support Services Director  
Cheryl Carpenter, Community Engagement  
Reggie Cooper, Planning & Development Director  
Alex Agnor, Asst. City Manager/Econ. Dev. & Strat. Init. Director  
Nikki Smith, City Secretary  
David Rainwater, Fire Chief

**2. Citizen Comments**

Texas Government Code, Sec. 551.007 requires that a governmental body must allow each member of the public who desires to address the body regarding an item on the agenda the opportunity to do so before or during the body's consideration of the item. The "Citizens Comments" portion of the meeting meets the requirements of this law and is the public's opportunity to speak on any item on the agenda. Those who wish to speak are requested to fill out a public comment form and will have three (3) minutes to speak unless additional time has been requested.

There were no citizen comments.

### 3. Discussion and Report for City Council Consideration and Direction

- A. Report on the Fire Fighter's Pension Fund August 26, 2025, meeting. Melissa Vossmer stated the Fire Fighters' Relief and Retirement (FFR&R) board met on Tuesday, August 26, 2025. Information from the board was given to the actuarial and more information will be provided in the coming weeks. Melissa Vossmer stated she would place an item on a future council meeting agenda.
- B. Restaurant Inspection Policy Discussion. Reggie Cooper, Planning & Development Director, provided information regarding the health inspection process for restaurants, the guidelines provided by the City Charter and Texas Food Establishment Rules (TFER) and explained that our Health Inspector, Olivia Cuenca, trained and separated from Harrison County but still inspects approximately 18–20 events, daycare centers, school cafeterias and concessions, and almost 300 restaurants in the City of Marshall.

Reggie Cooper explained the three (3) types of inspections: routine, compliance and complaint. Routine inspections are the only inspections that a grade is given for and are unannounced, compliance inspections are scheduled, and complaint inspections are unannounced. Reggie Cooper stated he reviewed the ordinances of surrounding cities and only one had a policy in place, but it was managed by a private entity, other cities charge reinspection fees and limit the number of times a reassessment is done.

Councilmember Abraham stated she is aware of the inspection process and thinks the City is following best practices as this is an important safety issue. The restaurants know inspections are going to take place.

Councilmember Campbell stated there was information provided that stated the grades could not change for six months. He asked that the department reevaluate the process for changing grades and that fees could be implemented according to HB 2156.

Reggie Cooper stated the department could look into implementing fees with consideration of the current economy and include looking at the historical inspection information of an establishment.

Councilmembers discussed the grading process, timeline, and requirements of inspections and asked how long a routine inspection takes, which is usually about three (3) hours. The current software being used issue a grade for every type of inspection, but this grade is not accurate for all types of inspections as not every box is checked for all inspections. New software is being researched to assist with the process.

### 4. Adjournment

**Councilmember Fenton made a motion to adjourn. Councilmember Abraham seconded the motion, which passed by a vote of 7:0.**

APPROVED:

ATTEST:

\_\_\_\_\_  
Mayor of the City Council  
of the City of Marshall, Texas

\_\_\_\_\_  
City Secretary



TO: City Council  
DATE: September 25, 2025  
ITEM #: 8.A  
SUBJECT: Conduct 2<sup>nd</sup> Public Hearing on the Proposed Budget for Fiscal Year 2026 and Consider approval of an ordinance to adopt the annual budget of the City of Marshall, Texas for the 2026 fiscal year.

**Recommendation for Action:** Conduct the 2<sup>nd</sup> of two Public Hearings regarding the proposed FY26 Budget and Adopt an Ordinance Approving

**Executive Summary:** The City Council approved a Resolution at the August 28th Regular Meeting, establishing two Public Hearings as part of the public input for the budget adoption process. This is the second scheduled Public Hearing per state statute. The City has posted the overview of the FY26 Budget which includes the Council's directed areas of focus and supporting implementation information.

As a matter of process, the proposed FY26 Budget is just that — proposed. As noted during the budget presentation on August 18th, there is no reduction in services or service delivery in the proposed FY26 Budget. The development of all the departmental budgets reflects this direction, and we built a budget that supports the City Council's Vision, Mission Statement and Focus Areas. The FY26 Budget will be finalized with Council decisions on the approved 1) Solid Waste / Recycling Rates, 2) Water / Sewer Rates, 3) Tax Rate and 4) determination of employee compensation over the next few weeks. The FY26 Budget will, in all likelihood, need to be amended as it will be a challenge to finalize the agreement on contributions to the Firefighters Pension as well as the time necessary for the membership to complete the voting process prior to September 25th. As such, I am including some limited flexibility to fund the agreed-upon contributions by the City.

Attachments Fiscal Year 2026 City Manager Budget Overview Presentation

**Focus Area(s):** The Proposed FY26 Budget supports all the Focus Areas identified by Council, including Improving Infrastructure, Improving Community Appearance, Investing in our Workforce, Improving Customer Service, and Improving Communication.

**Budget Cost:** N/A

**Staff Contact:** Melissa Byrne Vossmer, City Manager  
Julie Richards, Interim Budget Manager

**Attachments:** 1. Ordinance Adopting 2026 Budget

ORDINANCE NO. \_\_\_\_\_

**AN ORDINANCE MAKING APPROPRIATIONS FOR THE SUPPORT OF THE CITY OF MARSHALL, TEXAS, FOR THE FISCAL YEAR BEGINNING JANUARY 1, 2026 AND ENDING DECEMBER 31, 2026; APPROPRIATING MONEY TO A SINKING FUND TO PAY INTEREST AND PRINCIPAL DUE ON THE CITY’S INDEBTEDNESS; AND ADOPTING THE ANNUAL BUDGET OF THE CITY OF MARSHALL, TEXAS, FOR THE 2026 FISCAL YEAR.**

WHEREAS, the budget, as presented in Section 1 below, for the fiscal year beginning January 1, 2026 and ending December 31, 2026 was duly presented to the City Council by the City Manager and the Interim Budget Manager and a public hearing was ordered by the City Council and said notice was

published in the Marshall News Messenger and said public hearing was held according to said notice; now, therefore,

BE IT ORDAINED BY THE CITY COUNCIL OF THE CITY OF MARSHALL, TEXAS:

SECTION 1

THAT the appropriations for the fiscal year beginning January 1, 2026 and ending December 31, 2026 for the support of the City of Marshall, Texas, be fixed and determined for said term in accordance with the expenditures shown in the City’s fiscal year 2026 budget, as detailed below:

<u>FUND</u>	<u>TOTAL BUDGETED EXPENDITURES</u>
General Fund	\$ 26,306,951
Water & Sewer Enterprise Fund	\$ 12,900,593
Sub-Total -- Operating Budget	\$ 39,207,544
Structural Modification Fund	\$ 0
Hotel/Motel Occupancy Tax Fund	\$ 1,135,000
Municipal Court Technology Fund	\$ 0
Municipal Building Security Fund	\$ 10,500
Sanitation Fund	\$ 4,056,000
Library Endowment Fund	\$ 31,000
Wonderland of Lights Fund	\$ 272,000
LEOSE Fund - Police & Fire Department	\$ 5,650
Federal Forfeiture Fund - Police Department	\$ 5,600
Debt Service Funds	\$ 2,421,140
Fleet Management Fund	\$ 2,235,177
Marshall Pet Adoption Center Fund	\$ 0
Street Maintenance Fund	\$ 827,219
Emergency Medical Services - ESD Fund	\$ 200,500
State Forfeiture Fund - Police Department	\$ 40,000
Municipal Drainage Utility Fund	\$ 350,000
Tax Increment Reinvestment Zone - TIRZ Fund	\$ 67,000
Total Budget	\$ 50,864,330

SECTION 2 ~

THAT the budget, as shown in words and figures in Section 1, is hereby approved in all respects and adopted as the City's budget for fiscal year beginning January 1, 2026 and ending December 31, 2026.

PASSED, APPROVED, AND ADOPTED this, the 25<sup>th</sup> day of September, 2025.

Mayor Amy Ware, District 4	voted	_____
Mayor Pro-Tem Amanda Abraham, District 6	voted	_____
Councilmember Risa Jordan-Anderson, District 1	voted	_____
Councilmember Leo Morris, District 2	voted	_____
Councilmember Dathaniel Campbell, District 3	voted	_____
Councilmember Reba Godfrey, District 5	voted	_____
Councilmember Micah Fenton, District 7	voted	_____

**Total Ayes:** \_\_\_\_\_  
**Total Nays:** \_\_\_\_\_  
**Total Abstain:** \_\_\_\_\_  
**Total Absent:** \_\_\_\_\_

APPROVED:

\_\_\_\_\_  
MAYOR OF THE CITY COUNCIL  
OF THE CITY OF MARSHALL, TEXAS

ATTEST:

\_\_\_\_\_  
NIKKI SMITH  
CITY SECRETARY



TO: City Council  
 DATE: September 25, 2025  
 ITEM #: 8.B  
 SUBJECT: Conduct a public hearing and consider approval of an ordinance affixing and levying 2025 ad valorem taxes for the use and support of the municipal government of the City of Marshall for the 2026 fiscal year at a rate of \$0.5815183 per \$100 of property value, *which is effectively a 9.32 percent increase in the tax rate.* **The tax rate of \$0.5815183 will raise more taxes for maintenance and operations than last year's tax rate.** (Asst. City Manager)

**Recommendation for Action:** Following public hearing, consider approval of an ordinance affixing and levying 2025 ad valorem taxes for the use and support of the municipal government of the City of Marshall for the 2026 fiscal year at a rate of \$0.5815183 per \$100 of property value, which is effectively a 9.32 percent increase in the tax rate. The tax rate of \$0.5815183 will raise more taxes for maintenance and operations than last year's tax rate.

**Executive Summary:** In support of the FY2026 Annual Budget, staff is proposing a tax rate of \$0.5815183 per \$100 valuation for Tax Year 2025. This rate exceeds the lower of the no-new-revenue or voter-approval tax rate, and state law requires that a public hearing be held by the governing body before adopting the proposed tax rate.

<b>PROPOSED TAX RATE</b>	<b>\$0.5815183 per \$100</b>
PRECEDING YEAR'S TAX RATE	\$0.5790790 per \$100
NO-NEW-REVENUE TAX RATE	\$0.5318950 per \$100
VOTER-APPROVAL TAX RATE	\$0.5815183 per \$100

The no-new-revenue tax rate is the calculated rate that would raise about the same amount of property tax revenue for the City of Marshall as the prior year on properties taxed in both years.

The voter-approval tax rate is the maximum tax rate that the City of Marshall may adopt without voter approval. This rate divides property taxes into two categories – Maintenance and Operations (M&O) and Interest and Sinking (I&S, or debt rate). The voter-approval rate accounts for the M&O rate plus 3.5% adjusted for sales tax-property tax reduction, the unused increment rate, and the debt rate.

As outlined in the subject ordinance, the proposed tax rate of \$0.5815183 per \$100 valuation is apportioned as follows:

**Maintenance & Operations: \$0.488796**

**Interest & Sinking: \$0.0927228**

The public is urged to attend and express views on the proposed tax rate. Following the public hearing, the City Council will consider approval of an ordinance affixing and levying 2025 ad valorem taxes for the use and support of the municipal government of the City of Marshall for the 2026 fiscal year at a rate of \$0.5815183 per \$100 of property value, which is effectively a 9.32 percent increase in the tax rate. The tax rate of \$0.5815183 will raise more taxes for maintenance and operations than last year's tax rate.

On August 28, 2025, City Council approved Resolution No. R-25-14 announcing the proposed tax rate of \$0.5815183 per \$100 valuation and scheduling the subject public hearings. The first public hearing was held on September 11, 2025.

**Budget Cost:** N/A

**Staff Contact:** Alex Agnor, Assistant City Manager, Director of Economic Development & Strategic Initiatives, Interim Development Services Director

**Attachments:** Ordinance-2025 Tax Rate

ORDINANCE NO. \_\_\_\_\_

**AN ORDINANCE LEVYING AD VALOREM TAXES FOR 2025 AT A RATE OF \$0.5815183 PER \$100 OF ASSESSED VALUATION ON ALL TAXABLE PROPERTY FOR THE USE AND SUPPORT OF THE MUNICIPAL GOVERNMENT OF THE CITY OF MARSHALL, TEXAS, FOR THE 2026 FISCAL YEAR, IN ACCORDANCE WITH TEX. LOC. GOV'T CODE CHAPTER 102 AND TEXAS TAX CODE CHAPTER 26, AND BECOMING EFFECTIVE FROM AND AFTER ITS PASSAGE.**

**WHEREAS**, the City Council of the City of Marshall, Texas has heretofore approved and adopted the budget for the fiscal year 2026, beginning January 1, 2026, and ending December 31, 2026; and

**WHEREAS**, notice of the tax rate calculations for tax year 2025 for the City of Marshall, Texas was heretofore published in accordance with law; and

**WHEREAS**, it now becomes the duty of the City Council of the City of Marshall to set tax rates; and

**WHEREAS**, this year's levy to fund maintenance and operations expenditures does exceed last year's maintenance and operations tax levy; and,

**NOW, THEREFORE, BE IT ORDAINED BY THE CITY COUNCIL OF THE CITY OF MARSHALL, TEXAS:**

**Section 1.**

All of the above premises are found to be true and correct and are incorporated into the body of this ordinance as if copied in their entirety.

**Section 2.**

The real and personal property tax appraisal rolls as certified by the Chief Appraiser of the Harrison Central Appraisal District to the City Council for the 2025 property tax year, be and are hereby accepted.

**Section 3.**

That a tax is hereby levied upon all taxable property in the City of Marshall, Texas, the values of which have been certified by the Chief Appraiser of the Harrison Central Appraisal District, in accordance with Tex. Loc. Gov't Code Chapter 102 and Tex. Tax Code Chapter 26, at the rate of \$0.5815183 per \$100 valuation of property, said tax being apportioned to the specific purposes set forth as follows:

1. For the maintenance and operations, \$0.488796 on each \$100 valuation of property; and
2. For the interest and sinking fund, \$0.0927228 on each \$100 valuation of property.

**Section 4.**

That the taxes levied under this ordinance shall be for the use and support of the municipal government of the City of Marshall, Texas, for the fiscal year January 1, 2026 through December 31, 2026.

**Section 5.**

That **THIS TAX RATE WILL RAISE MORE TAXES FOR MAINTENANCE AND OPERATIONS THAN LAST YEAR'S TAX RATE.**

**Section 6.**

That **THE TAX RATE WILL EFFECTIVELY BE RAISED BY 5.91 PERCENT AND WILL RAISE TAXES FOR MAINTENANCE AND OPERATIONS ON A \$100,000 HOME BY APPROXIMATELY \$27.30.**

**Section 7.**

That taxes levied under this Ordinance are due January 31, 2026, and if not paid on or before February 1, 2026 shall immediately become delinquent.

**Section 8.**

That all taxes shall become a lien upon the property against which assessed, and the assessor and collector for the City of Marshall, Texas, is hereby authorized and empowered to enforce the collection of such taxes according to the Constitution and laws of the State of Texas and ordinances of the City of Marshall, Texas. All delinquent taxes shall bear interest and penalty from date of delinquency at the rate as prescribed by state law.

**Section 9.**

That the meeting at which this ordinance was passed was in all things conducted in strict compliance with the Texas Open Meetings Act, Texas Gov't. Code Chapter 551.

**Section 10.**

That this Ordinance shall be in full force and effect upon and after its passage and publication as required by law.

PASSED, APPROVED, AND ADOPTED this, the 25<sup>th</sup> day of September, 2025.

Mayor Amy Ware, District 4	voted _____
Mayor Pro-Tem Amanda Abraham, District 6	voted _____
Councilmember Risa Jordan-Anderson, District 1	voted _____
Councilmember Leo Morris, District 2	voted _____
Councilmember Dathaniel Campbell, District 3	voted _____
Councilmember Reba Godfrey, District 5	voted _____
Councilmember Micah Fenton, District 7	voted _____

APPROVED:

\_\_\_\_\_  
MAYOR OF THE CITY COUNCIL  
OF THE CITY OF MARSHALL, TEXAS

ATTEST:

\_\_\_\_\_  
NIKKI SMITH  
CITY SECRETARY



TO: City Council  
DATE: September 25, 2025  
ITEM #: 8.C  
SUBJECT: **O-25-XX** Conduct a public hearing and consider approval of an ordinance regarding a rezoning request for 1801 University Ave from R-2 (Single Family Detached) to R-6 (Duplex Triplex Quadraplex) (**P&Z Item ZBA-25-04**). (Development Services)

**Recommendation for Action:** Following the public hearing, consider approval of an ordinance regarding a rezoning request for 1801 University Ave from R-2 (Single Family Detached) to R-6 (Duplex Triplex Quadraplex) as recommended by the Planning & Zoning Commission.

**Executive Summary:** On July 14, 2025, the Planning and Zoning Commission conducted a public hearing to consider and make a recommendation to the City Council regarding a rezoning request of a 1.374+/- acre tract of land from R2 (Single Family Detached) to R6 (Duplex, Triplex, Quadplex), located at 1801 University Ave. (R31462.) Following the public hearing and discussion, a motion was made to recommend of the rezoning request to City Council for approval. The motion was seconded and passed by a vote of 4:1.

Mark Priestner, Halff and Associates, serves as the City's Planning Consultant and will assist in presenting the item to City Council for consideration.

**Focus Area(s):** This item aligns with the following council adopted focus area(s):

**Budget Cost:**

**Staff Contact:** Alex Agnor, Assistant City Manager/Economic Development & Strategic Initiatives Director/Interim Development Services Director

- Attachments:**
1. ZBA-25-04\_1801UniversityAve\_Rezone (P&Z Packet)
  2. ZBA-25-04-1801 University Protest Letter Responses
  3. ORD-O-25-XX-1801 University (ZBA-25-04)



**Background & Summary of Request:**

The applicant is requesting the zoning be changed from R2 (Single Family Detached) to R6 (Duplex, Triplex, Quadplex). The Applicant is proposing to construct a quadplex on the property which would provide for additional housing in the area near Wiley University.

**Picture of the Site:**



*Figure 2: Looking North on University Ave*



*Figure 3: Looking South on University Ave*

**Existing Conditions:**

The property is currently vacant and wooded, and relatively flat with a gentle slope to the south.

The table below outlines the surrounding zoning and land uses:

	<b>Zoning Classification</b>	<b>Land Use</b>
North of the Property	R2 (Single Family Detached)	Single Family Homes with some Duplexes

East of the Property	R2 (Single Family Detached)	Single Family Homes with some Duplexes and Wiley University
South of the Property	R2 (Single Family Detached)	Single Family Homes
West of the Property	R2 (Single Family Detached)	Single Family Homes

Water service is available along the frontage of the site by an existing 8” water main along the right-of-way of University Ave. There is an existing 6” sewer main located on the north side University Ave.

**Zoning Classification Analysis:**

The applicant is requesting a zoning change from R2 (Single Family Detached) to R6 (Duplexes, Triplexes, Quadplexes). The applicant has indicated on their application that the proposed lot will be developed with a quadplex housing type along with adequate off-street parking.

**Comprehensive Plan and Future Land Use Map Analysis:**

The Future Land Use map identifies this property as Agriculture and Estate along with future residential properties.

The following questions should be answered when determining if a zoning change is appropriate:

1. Will the proposed change be in compliance with the goals of the Comprehensive Plan?

*The request of R6 (Duplexes, Triplexes, Quadplexes) will be consistent with the Comprehensive Plan since there are other existing housing types in this area and will support student and faculty housing for Wiley University.*

2. Will there be an adverse impact on surrounding property if the request is approved? In evaluating this question, consideration should be given to all permitted uses in the proposed new zoning and the impact it could have on surrounding property.

*The surrounding property is currently zoned R2 with a mix of housing types including some preexisting legal nonconforming duplexes This requested change would not be a significant change in zoning as there are other residential housing types in the immediate area.*

3. Is the property suitable for use as it is currently zoned or does the zoning need to be changed to allow the property to be put to use in a way that is in keeping with the surrounding activities.

*As already stated, the property is currently surrounded by residential housing so changing the zoning would be a consistent use of the zoning district. It is anticipated that there will be additional rezoning request within some of the R2 zones to accommodate duplexes, triplexes and quadplexes as that type of housing stock has become very popular in the area.*

4. What is the relationship of the proposed change to the health, safety and welfare of the general community? In other words, will the change make the community better or is it merely for the convenience of the owner? Will surrounding property owners suffer or lose any enjoyment in the area of their property as a result of this change? Does the proposed change seem to be a logical extension of similar types of development?

*Based on existing conditions the proposed change/use will not have an immediate negative effect on the community.*

**Suggested Motions:**

1. Motion to recommend approval of case number ZBA-25-04 as requested.

CASE NUMBER/NAME: 1801 University Ave

Planning and Zoning Commission  
City of Marshall  
P.O. Box 698  
Marshall, TX 75671  
(903) 935-4407

Dear Commissioners:

Find listed below my opinion on the above referenced application which is scheduled for public hearing before the Planning and Zoning Commission on MONDAY, 7/14/25 at 6:00 p.m. and before the City Council on THURSDAY, 7/24/25 at 6:00 p.m. in the Jean Birmingham Council Chambers of City Hall, 401 S. Alamo Blvd.

I am **FOR** this Zone Change  I am **AGAINST** this Zone Change

---

---

---

---

---

Anita Peterson

Name (Please print)

Anita Peterson

Signature

1704 South Street

Mailing Address

903-407-1811

Phone #

6-30-2025

Date

CASE NUMBER/NAME: 1801 University Ave

Planning and Zoning Commission  
City of Marshall  
P.O. Box 698  
Marshall, TX 75671  
(903) 935-4407

Dear Commissioners:  
Find listed below my opinion on the above referenced application which is scheduled for public hearing before the Planning and Zoning Commission on MONDAY, 7/14/25 at 6:00 p.m. and before the City Council on THURSDAY, 7/24/25 at 6:00 p.m. in the Jean Birmingham Council Chambers of City Hall, 401 S. Alamo Blvd.

I am **FOR** this Zone Change  I am **AGAINST** this Zone Change

---

---

---

---

---

DeLores Marion

Name (Please print)

DeLores Marion

Signature

1705 South Street

Mailing Address

903-578-5880

Phone #

6-30-2025

Date

CASE NUMBER/NAME: 1801 University Ave

Planning and Zoning Commission  
City of Marshall  
P.O. Box 698  
Marshall, TX 75671  
(903) 935-4407

Dear Commissioners:

Find listed below my opinion on the above referenced application which is scheduled for public hearing before the Planning and Zoning Commission on MONDAY, 7/14/25 at 6:00 p.m. and before the City Council on THURSDAY, 7/24/25 at 6:00 p.m. in the Jean Birmingham Council Chambers of City Hall, 401 S. Alamo Blvd.

I am **FOR** this Zone Change \_\_\_\_\_ I am **AGAINST** this Zone Change

Property value will decrease, need single family dwellings.

Jeffrey L. Wilborn

Name (Please print)

Jeffrey L. Wilborn

Signature

1808 University Ave Marshall, Tx 75670

Mailing Address

817-707-5446

Phone #

7/11/25

Date

ORDINANCE NO O-25-

An Ordinance Amending Ordinance No. O-87-13 to rezone from R-2 to R-6 located at 1801 University (R31462) in Marshall, TX.

WHEREAS, the City of Marshall enacted zoning on December 13, 1951 and amended said ordinance on July 7, 1963 and on March 26, 1987 repealed and replaced all ordinance with Ordinance No. 0-87-13 amending the Code of Ordinances of the City of Marshall to add Chapter 32 regarding Zoning; and

WHEREAS, a Zoning District Map was adopted as a part of Ordinance No. 0-87-13; and

WHEREAS, Chapter 32, Section 14 of the Code of Ordinances established a procedure for a property owner, his agent, or the City to request zoning district map amendments; and

WHEREAS, the Planning & Zoning Commission, after due and proper notice in the manner and for the length of time required by law, held a public hearing for the purpose of considering proposed changes to the Zoning District Map; and

WHEREAS, after the close of said public hearing and pursuant thereto, the Planning & Zoning Commission filed a written report with the City Council, recommending changes in the Zoning District Map; and

WHEREAS, pursuant to said report and after notice in the manner and for the length of time required by law, the City Council held a public hearing in Marshall, Texas at City Hall on the 28<sup>th</sup> day of August, 2025 at 6:00pm for the purpose of considering the requested Zoning Map change, and at which hearing all property owners, interested parties, and interested citizens had an opportunity to be heard; and

WHEREAS, the City Council, after considering the proposed changes and after hearing all parties and citizens desiring to be heard, deems that the following changes are necessary and for the best interest of the general welfare of the citizens of the City of Marshall, Texas.

NOW, THEREFORE, BE IT ORDERED BY THE CITY COUNCIL OF THE CITY OF MARSHALL, TEXAS THAT:

Section 1. The facts and opinions in the preamble of this ordinance are true and correct.

Section 2. THAT THE ZONING MAP ESTABLISHED BY ORDINANCE NO. O-87-13 IS HEREBY AMENDED TO REZONE THAT CERTAIN LOT FROM R-2 TO R-6 LOCATED AT 1801 UNIVERSITY (R31462) IN MARSHALL, TX.

Section 3. All ordinances and agreements and parts of ordinances and agreements in conflict herewith are hereby repealed to the extent of the conflict only.

PASSED on the 25<sup>th</sup> day of September, 2025.

AYES: \_\_\_\_

NOES: \_\_\_\_

ABSTAINED: \_\_\_\_

\_\_\_\_\_  
MAYOR OF THE CITY COUNCIL  
OF THE CITY OF MARSHALL, TEXAS

ATTEST:

\_\_\_\_\_  
CITY SECRETARY



TO: City Council  
DATE: September 25, 2025  
ITEM #: 8.D  
SUBJECT: O-25-XX Conduct a public hearing and consider approval of an ordinance regarding a rezoning request for 3001 N East End Blvd from A-E (Agriculture & Estate) to C-3 (General Business) for Commercial Uses. **(P&Z Item ZBA-25-09)**. (Development Services)

**Recommendation for Action:** Following the public hearing, consider approval of an ordinance regarding a rezoning request for 3001 N East End Blvd from A-E (Agriculture & Estate) to C-3 (General Business), as recommended by the Planning & Zoning Commission.

**Executive Summary:** On September 8, 2025, the Planning and Zoning Commission conducted a public hearing to consider and make a recommendation to the City Council regarding a rezoning request of a +/-0.5 acre tract of land from A-E (Agriculture & Estate) to C-3 (General Business), located at 3001 N East End Blvd (R34433). Following the public hearing and discussion, a motion was made to recommend the rezoning request to City Council for approval. The motion was seconded and passed by a vote of 5:0.

Mark Priestner, Halff and Associates, serves as the City's Planning Consultant and will assist in presenting the item to City Council for consideration.

**Focus Area(s):** This item aligns with the following council adopted focus area(s):

**Budget Cost:**

**Staff Contact:** Alex Agnor, Assistant City Manager/Economic Development & Strategic Initiatives Director/Interim Development Services Director

- Attachments:**
1. ZBA-25-09 - Rezone 3001 N E End Blvd (P&Z Packet)
  2. 3001 N E End Blvd Response Letters
  3. ORD-O-25-XX-3001 N East End Blvd (ZBA-25-09)



## P&Z Agenda Information Sheet

### September 8, 2025

- A. ZBA-25-09: Conduct a public hearing to consider an application to rezone 3001 N East End Blvd from A-E (Agriculture & Estate) to C-3 (General Business) for Commercial Uses. Parcel # R34433.

Applicant:	Jeff Waldrop 546 PENNSYLVANIA AVE Marshall Texas 75672
Property Owner	Jeff Waldrop 546 PENNSYLVANIA AVE Marshall Texas 75672
Surrounding Property Notices	10 Notices Sent within 200 ft. of the Site 2 Responses (For)
<b>Location Map:</b>	

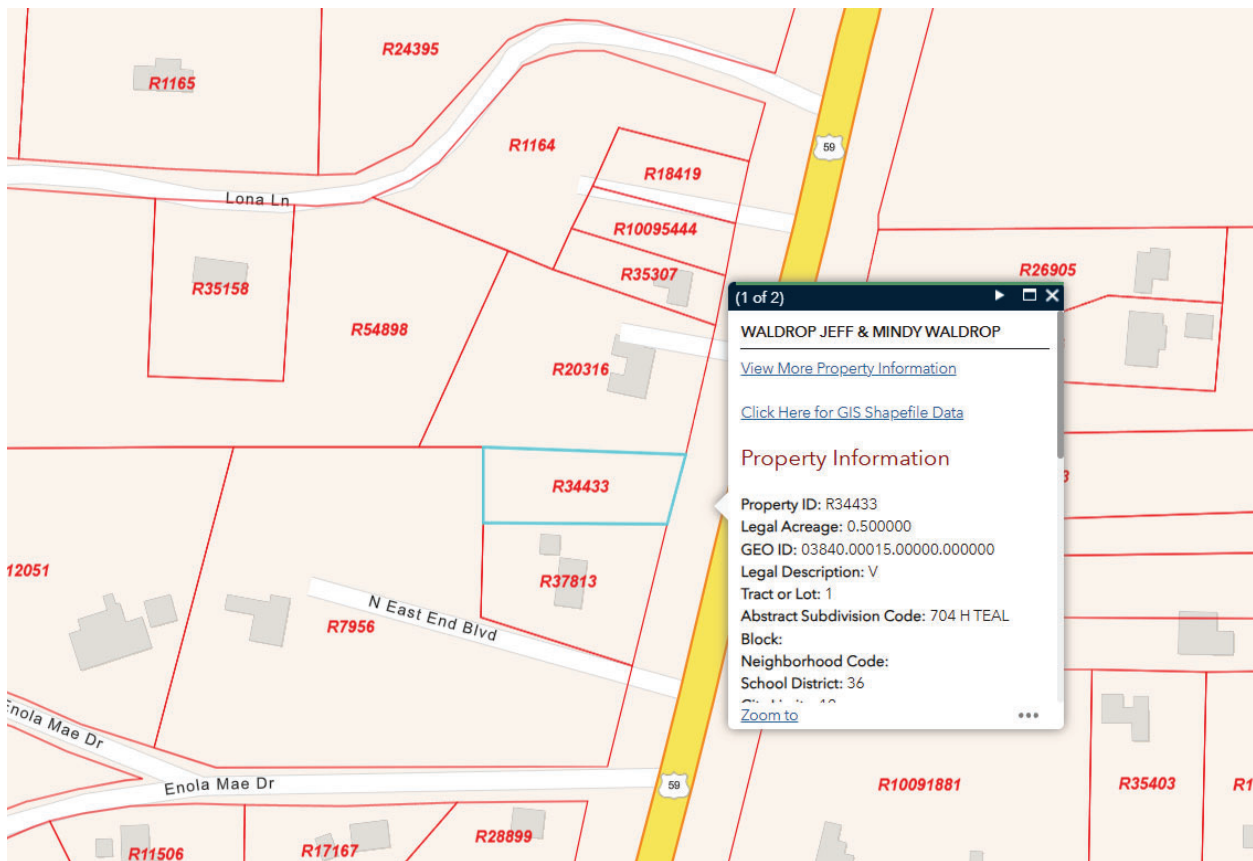

**Background & Summary of Request:**

The applicant is requesting approval of a zoning change to allow for commercial uses. This area is shown as Commercial Corridor on the Future Land Use map and the request is consistent with the Comprehensive Plan.

**Picture of the Site:**

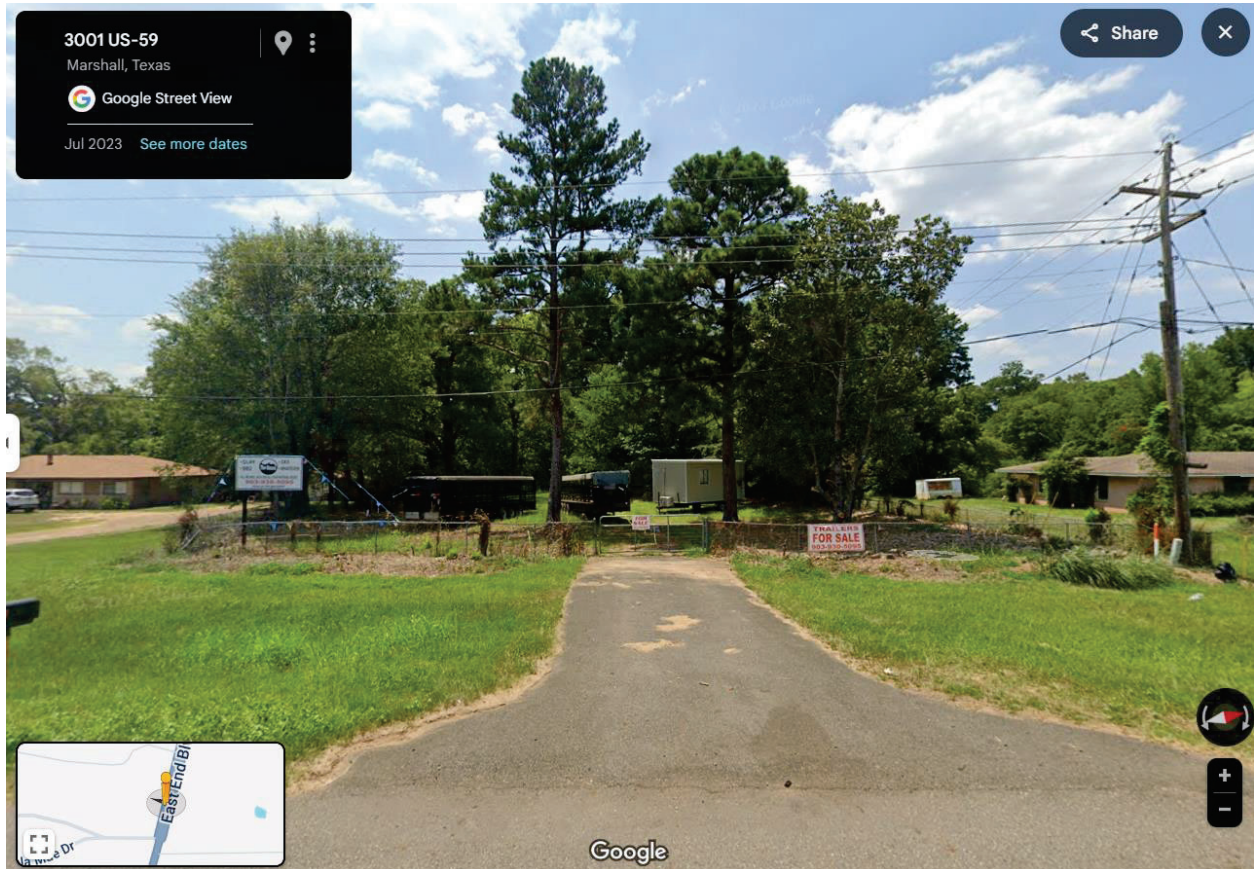

**Existing Conditions:**

Property is currently has no constructed structures. Property is zoned A&E (Agriculture and Estate) although the property to the north was rezoned to C-3 in the past month.

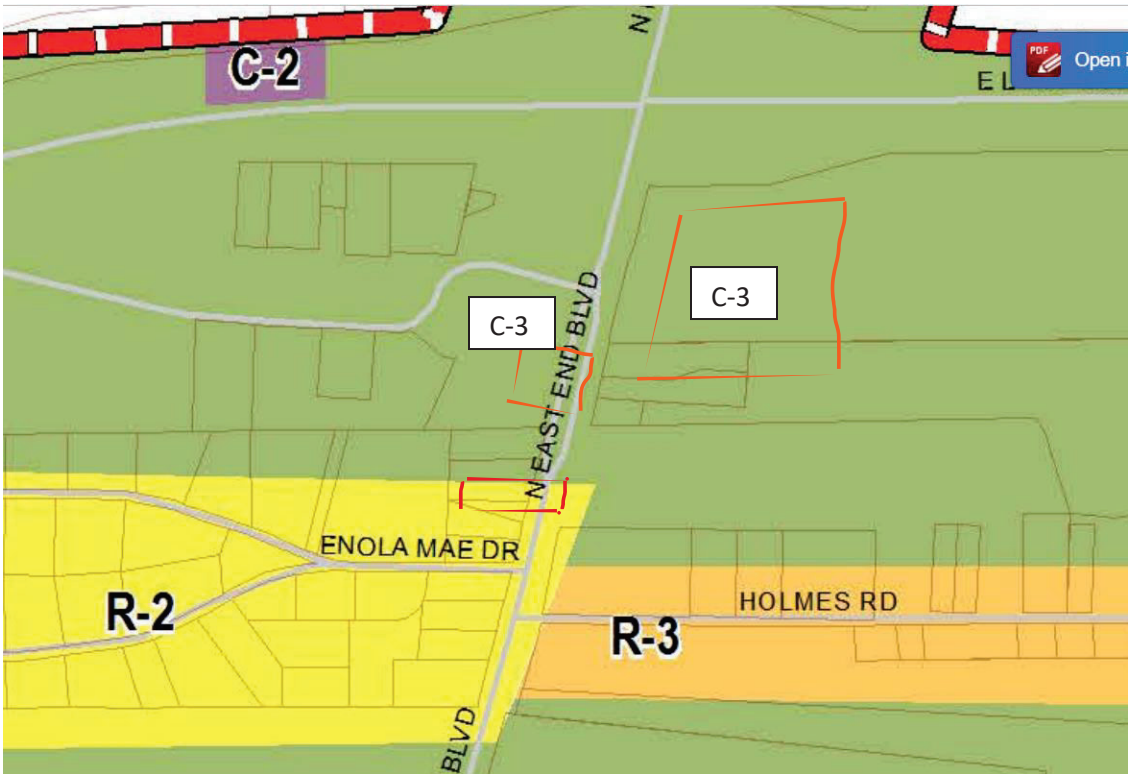

Utilities are available to the site.

**Comprehensive Plan and Future Land Use Map Analysis:** The Future Land Use map identifies this property as Commercial, Office, Service. The request is consistent with the Future Land Use Map.



**Reccomendation:**

1. Staff recommends approval of this request to change from AE to C-3.

**CASE NUMBER/NAME:** 3001 N E End Blvd

Planning and Zoning Commission  
City of Marshall  
P.O. Box 698  
Marshall, TX 75671  
(903) 935-4407

Dear Commissioners:  
Find listed below my opinion on the above referenced application which is scheduled for public hearing before the Planning and Zoning Commission on **MONDAY, 9/8/25** at 6:00 p.m. and before the City Council on **THURSDAY, 9/25/25** at 6:00 p.m. in the Jean Birmingham Council Chambers of City Hall, 401 S. Alamo Blvd.

I am **FOR** this Zone Change  I am **AGAINST** this Zone Change

\_\_\_\_\_  
\_\_\_\_\_  
\_\_\_\_\_  
\_\_\_\_\_  
\_\_\_\_\_

Michael Nash  
Name (Please print)

*Michael Nash*  
Signature

PO Box 277 Woodlawn TX 75694  
Mailing Address

903 930-5095  
Phone #

8-25-2025  
Date

CASE NUMBER/NAME: 3001 N E End Blvd

Planning and Zoning Commission  
City of Marshall  
P.O. Box 698  
Marshall, TX 75671  
(903) 935-4407

Dear Commissioners:  
Find listed below my opinion on the above referenced application which is scheduled for public hearing before the Planning and Zoning Commission on MONDAY, 9/8/25 at 6:00 p.m. and before the City Council on THURSDAY, 9/25/25 at 6:00 p.m. in the Jean Birmingham Council Chambers of City Hall, 401 S. Alamo Blvd.

I am **FOR** this Zone Change  I am **AGAINST** this Zone Change

\_\_\_\_\_  
\_\_\_\_\_  
\_\_\_\_\_  
\_\_\_\_\_  
\_\_\_\_\_

Name (Please print) Robert S. Wood

Signature Robert S. Wood

Mailing Address 2516 Holmes Rd

Phone # 903-930-5182

Date Sept 3, 2025

ORDINANCE NO \_\_\_\_\_

An Ordinance Amending Ordinance No. 0-87-13 To rezone 3001 N East End Blvd from A-E (Agriculture & Estate) to C-3 (General Business)

WHEREAS, the City of Marshall enacted zoning on December 13, 1951 and amended said ordinance on July 7, 1963 and on March 26, 1987 repealed and replaced all ordinance with Ordinance No. 0-87-13 amending the Code of Ordinances of the City of Marshall to add Chapter 32 regarding Zoning; and

WHEREAS, a Zoning District Map was adopted as a part of Ordinance No. 0-87-13; and

WHEREAS, Chapter 32, Section 14 of the Code of Ordinances established a procedure for a property owner, his agent, or the City to request zoning district map amendments; and

WHEREAS, the Planning & Zoning Commission, after due and proper notice in the manner and for the length of time required by law, held a public hearing for the purpose of considering proposed changes to the Zoning District Map; and

WHEREAS, after the close of said public hearing and pursuant thereto, the Planning & Zoning Commission filed a written report with the City Council, recommending changes in the Zoning District Map; and

WHEREAS, pursuant to said report and after notice in the manner and for the length of time required by law, the City Council held a public hearing in Marshall, Texas at City Hall on the 25<sup>th</sup> day of September, 2025 at 6:00pm for the purpose of considering the requested Zoning Map change, and at which hearing all property owners, interested parties, and interested citizens had an opportunity to be heard; and

WHEREAS, the City Council, after considering the proposed changes and after hearing all parties and citizens desiring to be heard, deems that the following changes are necessary and for the best interest of the general welfare of the citizens of the City of Marshall, Texas.

NOW, THEREFORE, BE IT ORDERED BY THE CITY COUNCIL OF THE CITY OF MARSHALL, TEXAS THAT:

Section 1. The facts and opinions in the preamble of this ordinance are true and correct.

Section 2. THAT THE ZONING MAP ESTABLISHED BY ORDINANCE NO. 087-13 IS HEREBY AMENDED TO REZONE THAT CERTAIN LOT from A-E (Agriculture & Estate) to C-3 (General Business) located at 3001 N East End Blvd in Marshall, Texas.

Section 3. All ordinances and agreements and parts of ordinances and agreements in conflict herewith are hereby repealed to the extent of the conflict only.

PASSED on the 25th day of September, 2025.

AYES: \_\_\_\_

NOES: \_\_\_\_

ABSTAINED: \_\_\_\_

\_\_\_\_\_  
MAYOR OF THE CITY  
COUNCIL OF THE CITY OF  
MARSHALL, TEXAS

ATTEST:

\_\_\_\_\_  
CITY SECRETARY



TO: City Council  
DATE: September 25, 2025  
ITEM #: 9.A  
SUBJECT: Consider approval for the purchase and installation of a new drive unit from RBIS, LLC. for the Wastewater Treatment Plant's Primary Clarifier #1. \$54,695.00. (Public Works)

**Recommendation for Action:** For Council to approve the purchase and installation of a new Drive Unit from RBIS, LLC. for the Wastewater Treatment Plant's Primary Clarifier #1 in the amount of \$54,695.00.

**Executive Summary:** In a primary clarifier, the Drive Unit powers the sludge rakes, which continuously scrape settled solids from the tank bottom and pumps them to the anaerobic digesters. It also drives a skimmer arm that removes scum and other floatables from the surface. By continuously removing sludge and floatables, the drive unit supports effective separation, prevents septic conditions, improves clarifier efficiency, and ensures the wastewater is properly conditioned for the next treatment stages.

To replace the existing drive unit and complete installation, three quotes were procured:

- **RBIS, LLC** – \$54,695.00
- **SGL Utility Contractors** – \$62,462.37
- **Francis Excavating** – \$65,850.00

**Focus Area(s):** This item aligns with the following council adopted focus area(s): Improving Infrastructure

**Budget Cost:** \$54,695.00

**Staff Contact:** Deck Shaver, Interim Director of Public Works  
Cory Owen, Assistant Director of Public Works

**Attachments:**

1. 1779\_001
2. 1780\_001
3. 1781\_001
4. 1782\_001



# RBIS, LLC.



PO Box 1364 ~ Texarkana, Tx. 75504  
Phone: (903) 701-3110 or (903) 701-3111  
Fax: (870)-772-0654  
bk.rbis@gmail.com

## PROPOSAL FOR PRIMARY CLARIFIER NEW DRIVE UNIT REPLACE

September 8, 2025

Corey Owens  
City of Marshall, Texas  
401 South Alamo Blvd  
Marshall, Tx. 75671

Phone: 903-934-7863  
Mbl: 903-578-3867

Job Name: **Replace and Reinstall New Drive Unit on Primary Clarifier 1**  
Job Location: **Marshall, Tx. – WWTP**

---

RBIS, LLC proposes to furnish material, labor, and equipment to purchase and install a new Hydratek Planetary Drive Unit (Model D30-BL) for the Primary Clarifier 1 at the Sewer Plant, per your request.

Anticipated Delivery is 18 Weeks

**Total Quoted Price for New Drive Installed - \$54,695.00**

### Exceptions: Exclusions:

Bonds & Permits  
Concrete Work/Repair of Any Kind

---

*Payment to be made as follows:*

**Due upon completion.**

All material is guaranteed to be as specified. All work is to be completed in a workmanlike manner, according to standard practices. Any alteration or deviation from above specifications involving extra costs will be executed only upon written orders, and will become an extra charge over and above the estimate. All agreements are contingent upon strikes, accidents, or delays beyond our control. Owner is to carry fire, tornado, and other necessary insurance.

**Note:** We reserve the right to withdraw this proposal if not accepted within 30 calendar days.

RBIS, LLC., Authorized Signature \_\_\_\_\_

**Acceptance of Proposal:** The above process, specifications and conditions are satisfactory and are hereby accepted. You are authorized to do the work as specified. Payment will be made as outlined above.

Signature: \_\_\_\_\_

Date of Acceptance: \_\_\_\_\_

SGL Utility Contractors

1885 Scarlet Oak  
 Gilmer, Texas 75645

# Estimate

Date	Estimate #
9/12/2025	Est #1

Name / Address
City of Marshall Cory Owen

Project	Job #
Estimate #1	

Description	Qty	Rate	Total
New D30-BL Planetary Drive Unit, includes new motor, digital load monitor, labor and will cutoff at 31,000 foot pounds	1	62,462.37	62,462.37
Material		6.75%	0.00
		<b>Total</b>	\$62,462.37



1356 S Kings Hwy  
Texarkana, TX 75501  
(903) 223-3774 office (903) 276-6021 cell

---

September 9, 2025

Cory Owen  
City of Marshall, TX  
401 South Alamo Blvd  
Marshall, TX 75671

RE: Replace Drive Unit on Primary Clarifier at WWTP

- ❖ Furnish and install a new D30-BL Drive Unit
  - Includes new motor
  - Includes digital load monitor that will cut off at 31,000 foot pounds
- ❖
- ❖ Anticipated delivery for drive unit is 18 weeks

**Total for this bid: \$65,850.00**

Exclusions:

Electrical  
Concrete Work

Please let me know if you have any questions!

Thank you,  
Greg Francis

ITEM NO.	DESCRIPTION	QTY.
1	Machine Frame	1
2	Internal 30 inch Gearbearing	1
3	Planetary/Plinion Assembly	1
4	L-Type Primary Speed Reducer	1
5	Drive Drum	1
6	Top Plate	1
7	Oil Fill & Inspection	1
8	Oil Drath	1
9	Cover Plate (Half)	2
10	Plug 2"-NPT	1
11	Bridge Pad	2

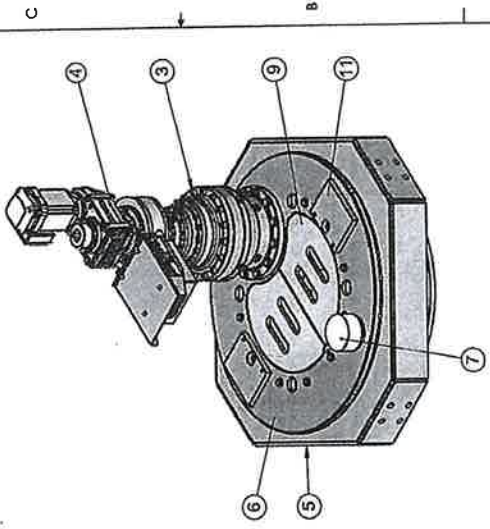
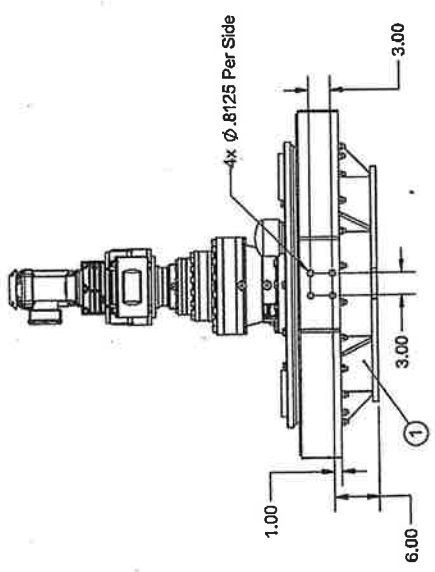
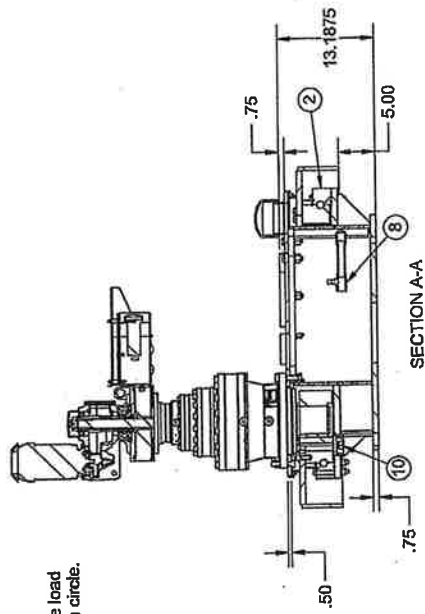
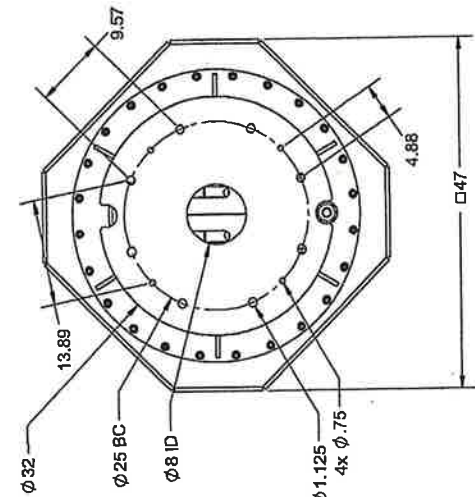
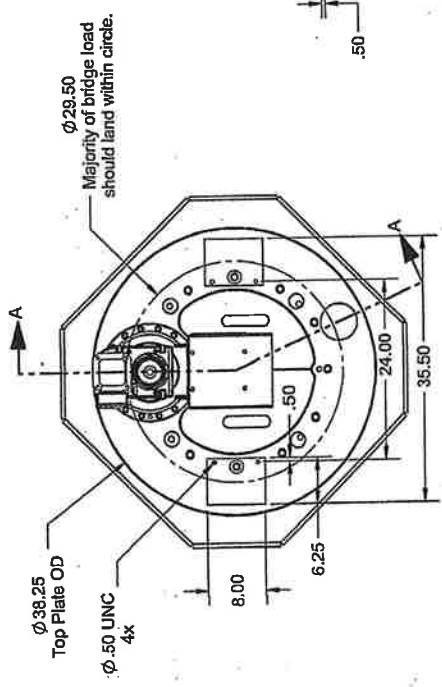

**DBS MANUFACTURING**  
 ATLANTA, GA, USA  
 WWW.DBSMFG.COM  
 404-768-2181

TITLE: General Arrangement

NAME	DATE
DRAWN	TBD
CHECKED	TBD
ENG APPR.	

COMMENTS:

UNLESS OTHERWISE SPECIFIED  
 DIMENSIONS ARE IN INCHES  
 DO NOT SCALE DRAWING  
 Project: TBD  
 PO: TBD

Drive Unit Settings	Clockwise Rotation (Viewed from top)	Model: D30-BL
Alarm:	TBD	Motor: 3/4hp, 230-460/3/60, 1800 rpm, TEFC
Cut-Off:	TBD	Continuous Rated Torque: 27,000 ft-lbs
Output RPM:	TBD	Maximum Rated Torque: 54,000 ft-lbs

**Coating**  
 Primer: Transox, Reschbus Reflec 1, Modified  
 Finish Coat: Transox, Granish-Green  
 Acrylic Polyurethane, ANSI 70 Light Gray  
 Touch-Up Paint: Spray Can: Resolium 214847  
 ANSI 70 Light Gray

SIZE	DWG. NO.	REV
B	D30-BL	

SCALE: 1:15 WEIGHT: 1832.169 LBS SHEET 1 OF 1



TO: City Council  
DATE: September 25, 2025  
ITEM #: 9.B  
SUBJECT: Consider approval to award a bid for electrical and plumbing work at the City Arena to LFA4 Enterprises, LLC (TIPS Contract 24010402), not to exceed \$61,136. (Facilities)

**Recommendation for Action:** The Facilities Department respectfully requests LFA4 Enterprise, LLC, be awarded approval of work to be done at the City Arena.

**Executive Summary:**

The scope of work consists of replacement of pedestals, including any and all electrical and plumbing work. The current state of our pedestals is in disarray, creating an electrically hazardous condition.

Earlier this year it was noted that there were major concerns with our pedestals. The pedestals, located at the City Arena, are where those with campers, RVs, horse trailers, etc. hook up for an electrical power source and water accessibility.

A scope of work was created, and LFA4 Enterprise, LLC, was the lowest bid. LFA4 is registered under The Interlocal Purchasing System (TIPS). In conjunction with our newly hired city manager's plan for the city, we have and will continue to focus on efficiency and improvement for our city's facilities as we continue to serve our citizens and guests. Some of this year's challenges brought about strains to our budget, mainly directed toward issues with aging equipment. However, the pedestals have become a safety concern to those attempting to use them. The City Arena hosts several events and thousands of visitors each year. Our department personnel have continued to work tirelessly to ensure our facilities are safe and meet industry standards.

Thank you for your continued support.

Sincerely,

A handwritten signature in black ink, appearing to read "Reginald Cooper".

Reginald Cooper  
Neighborhood Code Enforcement

**Focus Area(s):** This item aligns with the following council adopted focus area(s): Improving Infrastructure, Improving Community Appearance, Improving Customer Service.

**Budget Cost:** \$61,136

**Staff Contact:** Reggie Cooper

- Attachments:**
1. 9-25-25 Facility Proposal Acceptance Request for City Arena
  2. CITY.Commercial Construction ContractLFA4 Enterprises (002)

3. Exhibit A\_20250813\_0001
4. Certificate of Insurance LFA4 Enterprise, LLC
5. Layout Proposed for Pedestals City Arena

Marshall City Manager  
Marshall City Council  
City Of Marshall  
401 S. Alamo ST  
Marshall, Texas 75670

September 11, 2025

Dear City Manager and Council Members:

The Facilities Department respectfully requests LFA4 Enterprise, LLC be awarded approval of work to be done at the City Arena. The scope of work consists of replacement of pedestals, including any and all electrical and plumbing work. The current state of our pedestals is in disarray, creating an electrically hazardous condition.

Earlier this year it was noted that there were major concerns with our pedestals. The pedestals, located at the City Arena, are where those with campers, RVs, horse trailers, etc. hook up to for electrical power source and water accessibility.

A scope of work was created and LFA4 Enterprise, LLC was the lowest bid. LFA4 is registered under The Interlocal Purchasing System (TIPS). In conjunction with our newly hired City Manager's plan for the city, we have and will continue to focus on efficiency and improvement for our city's facilities as we continue to serve our citizens and guests. Some of this year's challenges brought about strains to our budget mainly directed toward issues with aging equipment, however the pedestals have become a safety concern to those attempting to use them. The City Arena hosts several events and thousands of visitors each year. As a glimmer of light, our department personnel have continued to work tirelessly to ensure our facilities are safe and meet industry standards.

Thank you for your continued support.

Sincerely,

A handwritten signature in black ink, appearing to read 'Reginald Cooper', enclosed within a large, loopy circular flourish.

Reginald Cooper  
Neighborhood Code Enforcement

**Commercial Construction Contract**  
**Terms**

**Date:** \_\_\_\_\_

**Owner:** The City of Marshall, Texas

**Owner's Mailing Address:**

The City of Marshall, Texas  
401 S. Alamo  
Marshall, Texas 75670  
Harrison County

**Contractor:** LFA4 Enterprise, LLC , or it's assigns.

**Contractor's Mailing Address:**

LFA4 Enterprise, LLC,  
279 Cr 4791  
Atlanta, Texas 75551,

**Property:**

As described in Exhibit A attached hereto and made a part thereof.

**Project Description:** Improvements to Marshall Arena located in Marshall , Texas, according to attached plans and specifications dated August 13, 2025

**Construction Terms**

Contract Sum:

Stipulated sum: \$ 61, 136.00

**Definitions**

"Plans" means the plans and specifications dated August 13, 2025 for the construction (dated and initialed by Owner and Contractor), attached hereto as Exhibit A.

"Improvements" means the improvements to be constructed on the Property according to the Plans.

The "Work" means the physical activities, materials, and equipment relating to the

**Commercial Construction Contract: Page 1**

construction of the Improvements.

"Commencement Date" means on or before October 1, 2025

"Completion Date" means the date of Substantial Completion and notice to Owner, but not later than October 31, 2025, unless extended by the terms of the Contract Documents, force majeure delays, or other delays not within Contractor's control.

"Concealed Conditions" means preexisting physical conditions situated below the surface of the ground, or concealed or unknown conditions in an existing structure, at variance with the conditions indicated in the Contract Documents or differing materially from those ordinarily encountered and generally recognized as inherent in Work of the character provided for in the Contract Documents.

"Contract Documents" means this commercial construction contract, the Plans, warranty documents, and any other documents governing the Work (collectively, the "Contract").

"Payment Deadline" means 2:00 P.M. on the tenth (10<sup>th</sup>) business day after Contractor's request for payment is received by Owner.

"Scope of Work" means the Work covered by the Contract Documents.

"Substantial Completion" or "Substantially Complete" means a certificate has been issued in which the parties stipulate the Improvements have been completed in accordance with the Plans and are fit for their intended use except for minor "punch list" items, which are typically completed or cured following the taking of possession by Owner.

### **Precommencement Matters**

#### **A. Contractor agrees to-**

1. Provide certificates of insurance.
2. Obtain Contractor's risk insurance coverage for casualty loss and public liability in the amount of \$ \$61,136.00 , to protect Contractor and Owner.
3. Provide water and electricity to the Property as needed for the Work.
4. CONTRACTOR shall at CONTRACTOR's own expense, purchase, maintain and keep in force during the term of this contract such insurance as set forth below. CONTRACTOR shall not commence work under this contract until CONTRACTOR has obtained all the insurance required under this contract and such insurance has been approved by City, nor shall CONTRACTOR allow any subcontractor to commence work on his or her own subcontract until all similar

insurance of the subcontractor has been obtained and approved. All insurance policies provided under this contract shall be written on an "occurrence" basis. The insurance requirements shall remain in effect throughout the term of this Contract. The policy limits stated below are at a minimum.

A. Workers' Compensation as provided by statute, Employers Liability Insurance of not less than \$1,000,000 for each accident, \$1,000,000 disease-each employee, \$1,000,000 disease-policy limit.

B. Commercial General Liability Insurance, including Independent Contractor's Liability, Completed Operations and Contractual Liability, covering but not limited to the indemnification provisions of this contract, fully insuring CONTRACTOR's liability for injury to or death of employees of City and third parties, extended to include personal injury liability coverage, and for damage to property of third parties, with a combined bodily injury and property damage minimum limit of \$1,000,000 per occurrence and a \$2,000,000 aggregate.

C. Commercial Automobile and Truck Liability Insurance, covering any auto or hired and non-owned vehicles, with a combined bodily injury and property damage limit of \$1,000,000 per occurrence.

D. Each insurance policy to be furnished by CONTRACTOR shall include the following conditions by endorsement to the policy:

Except for Worker's Compensation, the policy shall name City as an additional insured as to all applicable coverage. The additional insured shall extend to premises/operations and products/completed operations. Each policy will require that thirty (30) days prior to the cancellation of coverage, notice thereof shall be given to City to:

City of Marshall  
City Manager  
PO Box 698  
Marshall, Texas 75671

If the policy is canceled for nonpayment of premium, only ten (10) days advance written notice to City is required. CONTRACTOR shall also notify CITY within twenty-four (24) hours after receipt of any notices of expiration, cancellation, nonrenewal or any material change in coverage it receives from its insurer(s);

E. Insurance is to be placed with carriers with an A.M. Best rating of A:VII, or as otherwise acceptable to the City.

F. CONTRACTOR agrees to the following: 1. CONTRACTOR hereby waives subrogation rights for loss or damage to the extent same are covered by insurance. Insurers shall have no right of recovery or subrogation against City, it being the

intention that the insurance policies shall protect all parties to the contract and be primary coverage for all losses covered by the policies. 2. Companies issuing the insurance policies and CONTRACTOR shall have no recourse against City for payment of any premiums or assessments for any deductible, as all such premiums and deductibles are the sole responsibility and risk of CONTRACTOR. 3. Approval, disapproval or failure to act by City regarding any insurance supplied by CONTRACTOR (or any subcontractors) shall not relieve CONTRACTOR of full responsibility or liability for damages and accidents as set forth in the contract documents. Neither shall the insolvency or denial of liability by the insurance company exonerate CONTRACTOR from liability.

G. CONTRACTOR shall provide one (1) copy of a Certificates of Insurance completed on an Acord form or other State-approved form, and endorsements effecting coverage required by this section to the City by forwarding to:

City of Marshall  
City Manager  
PO Box 698  
Marshall, Texas 75671

**B. The following are stipulated:**

1. *Change Orders.* Contractor is under no duty to make any changes in the Plans requested by Owner without a written change order, executed by both parties.

2. *Consumer Products.* "Consumer Products," as defined by the Federal Trade Commission, are excluded from Contractor's warranty only to the extent individual manufacturers' warranties are passed through Contractor and assigned to Owner, with a copy received by Owner. Contractor assigns and passes through to Owner the manufacturers' warranties on all appliances and equipment. In the case of passed-through and received manufacturers' warranties on Consumer Products, Owner's recourse is directly to the manufacturer, and Contractor will have no responsibility for them, except for problems relating to Contractor's installation and hookup of the items.

3. *Consult Your Attorney.* This is intended to be a legally binding contract. READ IT CAREFULLY. If you do not understand the effect of any part of the Contract Documents, consult your attorney BEFORE signing.

**Following Completion of Pre-commencement Matters**

**A. Contractor agrees to-**

**Commercial Construction Contract: Page 4**

1. Commence the Work on or before October 1, 2025
2. Diligently prosecute the Work to completion and substantially complete the Work according to the Plans by the Completion Date.
3. Pay all valid bills and charges, less ten percent (10%) retainage, to any subcontractor for material or labor relating to the Improvements.
4. Keep the Property free from claims of liens for labor or material arising directly through Contractor, except that Contractor may reasonably dispute any claim.
5. Assist Owner in signing and filing an Affidavit of Commencement, if needed, in accordance with the Texas Property Code.
6. Provide all materials necessary for the construction except as specifically agreed in writing by the parties.

**B. Contractor agrees not to delay the work.**

**C. Owner agrees to-**

1. Pay to Contractor the Contract Sum, disbursed according to the contract terms, no later than the Payment Deadline. If Owner withholds payment on any specific item, then Owner shall deliver to Contractor written notice, on the same timetable as payment, on each specific item not accepted, with specific reasons and reasonable requirements stated for curing the non-acceptance. Owner shall not be required to pay more than the percentage of progress of the work (less ten percent (10%) retainage). Contractor shall submit invoices for services rendered, based upon the value of the services provided as set forth in the June 19<sup>th</sup>, 2025 scope of work attached hereto as Exhibit A . Owner shall make payments in the amount shown by Contractor approved invoices by the Payment Deadline. The retainage shall be released upon formal acceptance of the completed project by the Owner. Nothing contained in this Contract shall require Owner to pay for any work that is unsatisfactory as determined by Owner or which is not submitted in compliance with the terms of this Contract. Owner will not be required to make any payments to CONTRACTOR when CONTRACTOR is in default under this Contract, nor shall this paragraph constitute a waiver of any right, at law or in equity, which Owner may have if CONTRACTOR is in default, including the right to bring legal action for damages or for specific performance of this Contract. Waiver of any default under this Contract shall not be deemed a waiver of any subsequent default. CONTRACTOR will fully comply with any and all applicable federal, state and local laws relating to income reporting, including but not limited to Internal Revenue Service Reports

2. Provide the following materials in advance of the Commencement of the project:  
55 Pedestals and one dumpster for debris removal.

**Commercial Construction Contract: Page 5**

**D. Owner agrees not to-**

1. Communicate directly with laborers about the Work.
2. Delay or interfere with the progress of the Work.

**E. Contractor and Owner agree that-**

1. If Owner, at any time before or during the progress of the Work, wants any modifications made to the Plans ("Changed Work"), Owner will request in writing that Contractor undertake the Changed Work. If Contractor agrees to do the Changed Work, Contractor shall submit to Owner an estimate of the cost of the Changed Work and an extension of the Completion Date to reflect the additional time required for completing it. All additional work for which Owner may be charged shall only be performed upon the execution by both parties of a written change order. If a written change order is not obtained prior to performance of the work, all work shall be deemed to be work originally contemplated hereunder. If a preapproved written change order is not obtained, Contractor may submit to Owner the notice of change order and extension of time in writing, and the failure of Owner to make written objection within ten days of the notice is conclusively deemed approval by Owner. The Contract Sum and the Completion Date will be subject to being adjusted as set forth in the written agreed change order.

2. Should Contractor encounter Concealed Conditions, the Contract Sum will be equitably adjusted by change order on claim by either party made within twenty days after notice by Contractor to Owner of the Concealed Conditions.

3. Contractor occupies the status of an independent contractor, as that term is defined in the construction industry.

4. Unless otherwise specifically provided, reference to any equipment, material, article, or patented process by trade name, make, or catalog number is regarded as establishing a standard of quality and is not construed as limiting competition. Contractor may, at Contractor's option, use any equipment, material, article, or patented process that is substantially equal to that named.

5. Contractor has the right to subcontract any part or all of the Work, but shall be responsible for the performance of the work.

**Following Substantial Completion**

**A. Contractor agrees to-**

**Commercial Construction Contract: Page 6**

1. Remove debris and surplus materials occasioned by the Work.
2. Notify Owner on Substantial Completion of the Work and file an affidavit of completion in the real property records of the county in which the Property is located.
3. Deliver possession of the Improvements to Owner on the day following the later of Substantial Completion or final payment to Contractor of the Contract Sum.
4. Release the Work and Property from all claims, including claims of subcontractors and materialmen, on receipt of final payment.

**B. Owner agrees to-**

1. Pay to Contractor the final payment of the Contract Sum, including retainage thirty (30) days after completion, including all amounts due under the Contract Documents, upon the receipt of lien waivers or releases from all subcontractors and materialmen.
2. Sign and file for record within five days after Substantial Completion a notice of substantial completion and acceptance.

**C.** Owner and Contractor agree that Owner's acceptance of possession will be conclusively presumed to constitute Owner's acceptance of the Improvements as Substantially Complete and inhabitable.

**Default and Termination**

1. *Precommencement Matters.* If the Precommencement Matters have not been completed within ten days from the Contract Date, Owner or Contractor may unilaterally terminate this Contract by written notice within twenty days from the Contract Date, in which case this Contract will terminate, and the performing party is entitled to recover reasonable out-of-pocket costs from the nonperforming party.
2. *Owner's Default.* Each of the following constitutes a material breach of this Contract by Owner ("Owner's Default"): (a) failing to fully and timely perform any covenant of Owner under this Contract; (b) making any representation to Contractor found to be materially false, misleading, or erroneous; and (c) substantially breaching any of Owner's obligations under this Contract.
3. *Contractor's Default.* Each of the following constitutes a material breach of this Contract by Contractor ("Contractor's Default"): (a) delaying the Work such that the progress of

the Substantial Completion of the Improvements falls more than ten days behind the time shown for completion of the Work; (b) failing to fully and timely perform any covenant of Contractor under this Contract; (c) making any representation to Owner found to be materially false, misleading, or erroneous; and (d) substantially breaching any of Contractor's obligations under this Contract.

4. *Remedies.* If one party defaults, and the default is not cured within ten days of written notice specifically describing the default in addition to all other applicable remedies for breach of contract, this Contract may be terminated by written notice from the nondefaulting party to the defaulting party. In addition, if the defaulting party is the Contractor, Owner may take over the work after termination and Contractor shall be liable for any additional reasonable costs by Owner to complete the work. Unless extended as allowed hereunder, if the work is not completed by the Completion Date, Contractor shall be liable to Owner for liquidated damages of Five Hundred and No/100 Dollars (\$500.00) for each day after the Completion Date.

### **Miscellaneous Provisions**

1. *Agreement of Parties.* The Contract Documents, together with any attachments, constitute the entire agreement of the parties, and there are no oral agreements.

2. *Amendment of Contract.* This Contract may be amended only by an instrument in writing signed by the parties.

3. *Attorney's Fees.* If either party retains an attorney to enforce this Contract, the party prevailing in litigation is entitled to recover reasonable attorney's fees, court and other costs, and related expenses.

4. *Binding Effect.* This Contract binds, benefits, and may be enforced by the parties and their respective representatives, successors in interest, and, if permitted, their assigns.

5. *Counterparts.* If this Contract is executed in multiple counterparts, all counterparts taken together will constitute this Contract.

6. *Venue.* Venue is exclusively in Harrison County, Texas

7. *Notices.* Any notice required or permitted under this Contract must be in writing. Any notice required by this Contract will be deemed to be delivered (whether actually received or not) when deposited with the United States Postal Service, postage prepaid, certified mail, return receipt requested, and addressed to the intended recipient at the address shown in this Contract. Notice may also be given by regular mail, personal delivery, courier delivery, facsimile transmission, or other commercially reasonable means and will be effective when actually received. Any address for notice may be changed by written notice delivered as provided herein.

8. *Time* Time is of the essence. Unless otherwise specified, all references to days mean calendar days. Business days exclude all Saturdays, Sundays, and national holidays. If the date for performance of any obligation falls on a Saturday, Sunday, or national holiday, that obligation is performable on the next business day.

9. *Indemnification.* CONTRACTOR does hereby covenant and contract to indemnify and hold harmless CITY and all of its officials, officers, agents, employees and invitees, in both their public and private capacities, from any and all liability, claims, suits, demands or causes of action, including reasonable attorney fees of litigation and/or settlement, that may arise by reason of death of or injury to persons or damage to or loss of use of property occasioned by any wrongful intentional act or omission of CONTRACTOR as well as any negligent omission, act or error of CONTRACTOR, its officials, officers, agents, employees and invitees, or other persons for whom CONTRACTOR is legally liable with regard to the performance of this Contract, whether said negligence is sole negligence, contractual comparative negligence, concurrent negligence or any other form of negligence. In the event of joint or concurrent negligence of CONTRACTOR and CITY, responsibility, if any, shall be apportioned comparatively in accordance with the laws of the State of Texas. Nothing in this paragraph is intended to waive any governmental immunity available to CITY under Texas law or waive any defenses of CONTRACTOR or CITY under Texas law. This paragraph shall not be construed for the benefit of any third party, nor does it create or grant any right or cause of action in favor of any third party against CITY or CONTRACTOR.

10. *Conflict of Interest.* CONTRACTOR covenants and agrees that CONTRACTOR and its associates and employees will have no interest and will acquire no interest, either direct or indirect, which will conflict in any manner with the performance of the services called for under this Contract. All activities, investigations and other efforts made by CONTRACTOR pursuant to this Contract will be conducted by employees, associates or subcontractors of CONTRACTOR.

11. *Equal Opportunity Employment.* CONTRACTOR shall not discriminate against any employee or applicant for employment because of race, age, color, religion, sex, ancestry, national origin, place of birth or disability. CONTRACTOR shall take affirmative action to ensure that applicants are employed and that employees are treated during their employment without regard to their race, age, color, religion, sex, ancestry, national origin, place of birth or disability. This action shall include but not be limited to the following: employment, upgrading, demotion or transfer, recruitment or recruitment advertising; layoff or termination; rates of pay or other forms of compensation; and selection of training, including apprenticeship.

12. *HUB Businesses.* In performing this contract, CONTRACTOR agrees to use diligent efforts to purchase all goods and services from Marshall businesses whenever such goods and services are comparable in availability, quality and price. As a matter of policy with respect to CITY projects and procurements, CITY also encourages the use, if applicable, of qualified contractors, subcontractors and suppliers where at least fifty-one percent (51%) of the ownership

of such contractor, subcontractor or supplier is vested in racial or ethnic minorities or women. In the selection of subcontractors, suppliers or other persons in organizations proposed for work on this Contract, the CONTRACTOR agrees to consider this policy and to use its reasonable and best efforts to select and employ such company and persons for work on this Contract.

13. *Anti-Boycott Provision. Anti-Boycott Israel Provision.* Pursuant to Chapter 2271 of the Texas Government Code, the CONTRACTOR verifies by signing this Contract that the CONTRACTOR does not boycott Israel and will not boycott Israel during the term of this Contract. *Anti-Boycott Energy Companies Provision.* Pursuant to Chapter 2276.02 of the Texas Government Code, CONTRACTOR verifies by signing this Contract that CONTRACTOR does not boycott energy companies and will not boycott energy companies during the term of this Contract. *Prohibition on Contracts with Companies that Discriminate Against Firearm and Ammunition Industries.* Pursuant to Chapter 2274.002 of the Texas Government Code, CONTRACTOR verifies by signing this Contract that it does not have a practice, policy, guidance, or directive that discriminates against a firearm entity or firearm trade association and that it will not discriminate against a firearm entity or firearm trade association during the term of this Contract.

14. *Assignment by Contractor.* This contract may not be assigned without restriction by Contractor without the written consent of Owner.

15. *Severability.* If any of the terms, provisions, covenants, conditions or any other part of this Contract are held for any reason to be invalid, void or unenforceable, the remainder of the terms, provisions, covenants, conditions or any other part of this Contract shall remain in full force and effect and shall in no way be affected, impaired or invalidated.

16. When the context requires, singular nouns and pronouns include the plural

The City of Marshall, Texas, A Home Rule  
Municipality

By:  
Melissa Vossmer, City Manager

LFA4 Enterprise, LLC , a Texas limited liability  
company

By:  
Frank Allday, IV Managing Member and  
Authorized Representative



Frank Allday  
Cell- 903-244-1793  
Email- [fallday4@hotmail.com](mailto:fallday4@hotmail.com)

8/13/2025

Jerry Davis  
City of Marshall, Tx.

RE: Marshall Arena- Electrical and Plumbing Work

TIPS Contract 24010402 Trades, Labor, and Materials(JOC)

Mr. Davis,

Thank you for the opportunity to bid the following work:

\*Plumbing- Install approximately 1,000 feet of 1 ½ inch water line from the existing water service to 55 RV locations. Shut off valve and valve box will be installed to each RV electrical pedestal. Piping will transition to PEX above ground and will be strapped to the pedestal. Cladding will be installed around insulation to prevent sun damage.

\*Electrical- Removal of all old existing RV pedestals. Installation of 55 new RV pedestals supplied by the City of Marshall. Six-200 AMP Raintight Outdoor Disconnects. Each pedestal will have 2 bags of sakrete poured at the base of each pedestal. All wiring to new pedestals will be wired with PVC conduit and electrical wire. 1-20 ft. wooden pole with two LED parking lot floodlights. Removal of existing debris from old pedestals placed in dumpster provided by the City of Marshall.

Bid Price- \$61,136.00

Please contact me with any questions.

Respectfully submitted,

  
Frank Allday IV



# CERTIFICATE OF LIABILITY INSURANCE

DATE (MM/DD/YYYY)

08/29/2025

THIS CERTIFICATE IS ISSUED AS A MATTER OF INFORMATION ONLY AND CONFERS NO RIGHTS UPON THE CERTIFICATE HOLDER. THIS CERTIFICATE DOES NOT AFFIRMATIVELY OR NEGATIVELY AMEND, EXTEND OR ALTER THE COVERAGE AFFORDED BY THE POLICIES BELOW. THIS CERTIFICATE OF INSURANCE DOES NOT CONSTITUTE A CONTRACT BETWEEN THE ISSUING INSURER(S), AUTHORIZED REPRESENTATIVE OR PRODUCER, AND THE CERTIFICATE HOLDER.

**IMPORTANT:** If the certificate holder is an ADDITIONAL INSURED, the policy(ies) must have ADDITIONAL INSURED provisions or be endorsed. If SUBROGATION IS WAIVED, subject to the terms and conditions of the policy, certain policies may require an endorsement. A statement on this certificate does not confer rights to the certificate holder in lieu of such endorsement(s).

<b>PRODUCER</b> Offenhauer & Co. - Atlanta 205 W Main  Atlanta TX 75551		<b>CONTACT NAME:</b> Yolanda Williams <b>PHONE (A/C, No, Ext):</b> (903) 796-4104 <b>E-MAIL ADDRESS:</b> ywilliams@fwoins.com		<b>FAX (A/C, No):</b> (903) 796-5051	
<b>INSURED</b>  LFA4 Enterprise LLC 279 CR 4791  Atlanta TX 75551		<b>INSURER(S) AFFORDING COVERAGE</b>		<b>NAIC #</b>	
		<b>INSURER A:</b> Scottsdale Insurance Company		41297	
		<b>INSURER B:</b> PROGRESSIVE COUNTY MUTUAL INS CO		29203	
		<b>INSURER C:</b> Texas Mutual Insurance Company		22945	
		<b>INSURER D:</b>			
		<b>INSURER E:</b>			
		<b>INSURER F:</b>			

**COVERAGES****CERTIFICATE NUMBER:** 24/25 CAU WC 25/26 GL**REVISION NUMBER:**

THIS IS TO CERTIFY THAT THE POLICIES OF INSURANCE LISTED BELOW HAVE BEEN ISSUED TO THE INSURED NAMED ABOVE FOR THE POLICY PERIOD INDICATED. NOTWITHSTANDING ANY REQUIREMENT, TERM OR CONDITION OF ANY CONTRACT OR OTHER DOCUMENT WITH RESPECT TO WHICH THIS CERTIFICATE MAY BE ISSUED OR MAY PERTAIN, THE INSURANCE AFFORDED BY THE POLICIES DESCRIBED HEREIN IS SUBJECT TO ALL THE TERMS, EXCLUSIONS AND CONDITIONS OF SUCH POLICIES. LIMITS SHOWN MAY HAVE BEEN REDUCED BY PAID CLAIMS.

INSR LTR	TYPE OF INSURANCE	ADDL INSD	SUBR WVD	POLICY NUMBER	POLICY EFF (MM/DD/YYYY)	POLICY EXP (MM/DD/YYYY)	LIMITS	
A	<input checked="" type="checkbox"/> <b>COMMERCIAL GENERAL LIABILITY</b> <input type="checkbox"/> CLAIMS-MADE <input checked="" type="checkbox"/> OCCUR GEN'L AGGREGATE LIMIT APPLIES PER: <input type="checkbox"/> POLICY <input checked="" type="checkbox"/> PRO-JECT <input type="checkbox"/> LOC OTHER:			CPS8175290	03/20/2025	03/20/2026	EACH OCCURRENCE	\$ 1,000,000
							DAMAGE TO RENTED PREMISES (Ea occurrence)	\$ 100,000
							MED EXP (Any one person)	\$ 5,000
							PERSONAL & ADV INJURY	\$ 1,000,000
							GENERAL AGGREGATE	\$ 2,000,000
							PRODUCTS - COMP/OP AGG	\$ 2,000,000
								\$
B	<b>AUTOMOBILE LIABILITY</b> <input type="checkbox"/> ANY AUTO <input type="checkbox"/> OWNED AUTOS ONLY <input checked="" type="checkbox"/> SCHEDULED AUTOS <input checked="" type="checkbox"/> HIRED AUTOS ONLY <input checked="" type="checkbox"/> NON-OWNED AUTOS ONLY			975590287	12/12/2024	12/12/2025	COMBINED SINGLE LIMIT (Ea accident)	\$ 1,000,000
							BODILY INJURY (Per person)	\$
							BODILY INJURY (Per accident)	\$
							PROPERTY DAMAGE (Per accident)	\$
								\$
	<b>UMBRELLA LIAB</b> <input type="checkbox"/> OCCUR <b>EXCESS LIAB</b> <input type="checkbox"/> CLAIMS-MADE DED <input type="checkbox"/> RETENTION \$ <input type="checkbox"/>						EACH OCCURRENCE	\$
							AGGREGATE	\$
								\$
C	<b>WORKERS COMPENSATION AND EMPLOYERS' LIABILITY</b> ANY PROPRIETOR/PARTNER/EXECUTIVE OFFICER/MEMBER EXCLUDED? (Mandatory in NH) <input type="checkbox"/> Y/N If yes, describe under DESCRIPTION OF OPERATIONS below		N/A	0002117474	10/01/2024	10/01/2025	<input checked="" type="checkbox"/> PER STATUTE <input type="checkbox"/> OTHER	
							E.L. EACH ACCIDENT	\$ 1,000,000
							E.L. DISEASE - EA EMPLOYEE	\$ 1,000,000
							E.L. DISEASE - POLICY LIMIT	\$ 1,000,000

DESCRIPTION OF OPERATIONS / LOCATIONS / VEHICLES (ACORD 101, Additional Remarks Schedule, may be attached if more space is required)

**CERTIFICATE HOLDER****CANCELLATION**

City of Marshall 401 S Alamo Blvd  Marshall TX 75670	SHOULD ANY OF THE ABOVE DESCRIBED POLICIES BE CANCELLED BEFORE THE EXPIRATION DATE THEREOF, NOTICE WILL BE DELIVERED IN ACCORDANCE WITH THE POLICY PROVISIONS.  AUTHORIZED REPRESENTATIVE 
---	--

© 1988-2015 ACORD CORPORATION. All rights reserved.

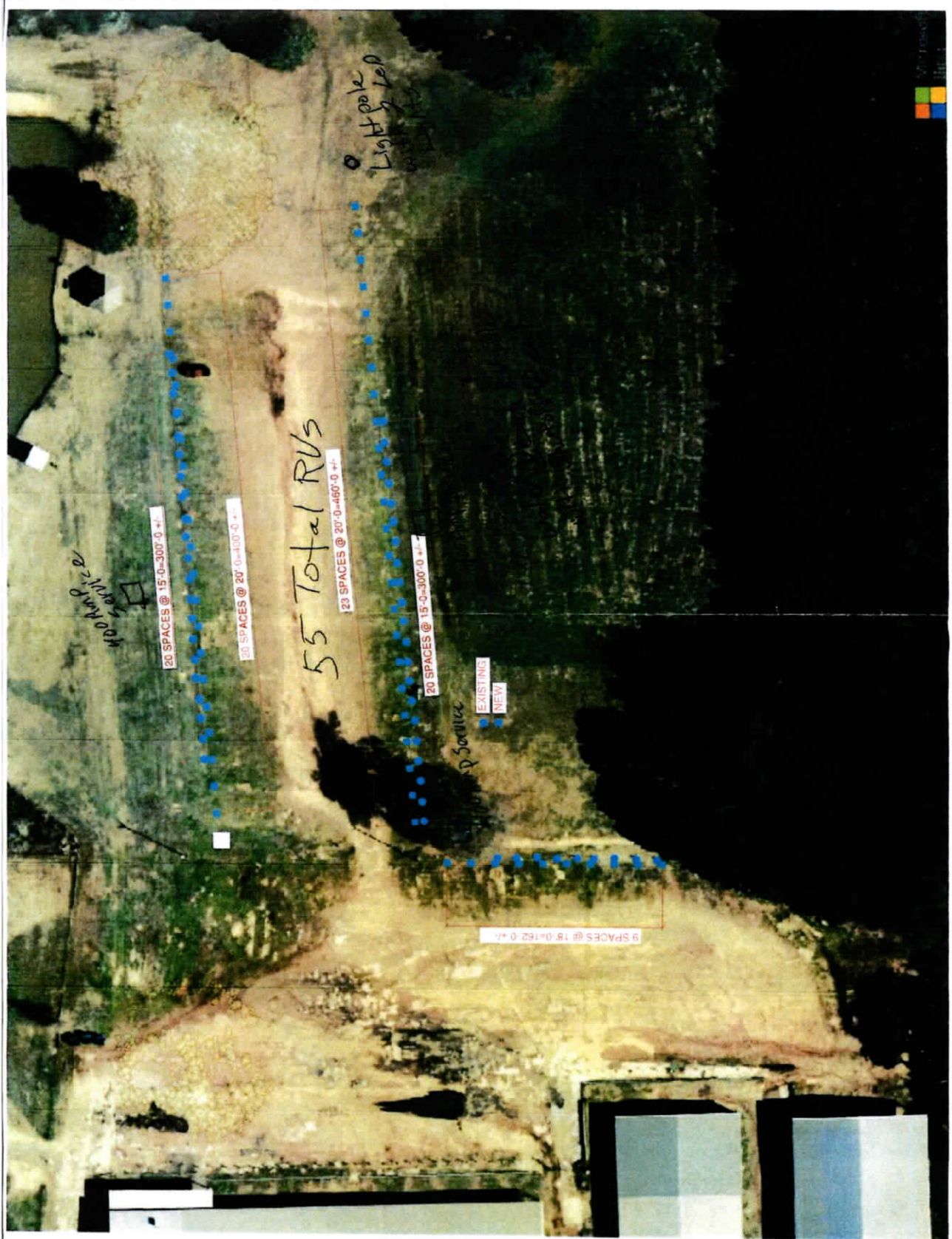



TO: City Council  
DATE: September 25, 2025  
ITEM #: 10.A  
SUBJECT: Discussion regarding the need to establish a Charter Review Committee. (Councilmembers Godfrey, Jordan – Anderson & Morris)

**Recommendation for Action:** Provide direction to Staff to bring back an item for Council approval to establish a Charter Committee, composition and timeline.

**Executive Summary:** The City of Marshall Charter specifically states:

Section 12.08 Charter Amendment

*Amendments to this Charter may be framed and submitted to the voters of the City in the manner prescribed by state law. The Council shall, at intervals not to exceed five (5) years, formally consider the need for revision(s) to the Charter. This review shall be based on a written report from the City Manager, with special attention given to conflicts, if any, between the Charter and state law, and recommending such amendments to the Charter as may seem necessary for legal, administrative or other reasons.*

The City Charter went through a complete review, which was initiated in late 2019, and voters considered and approved a series of amendments in the election of November 2020. This was the first time since being adopted in 1909, that amendments had been approved, though efforts were made in 1999 but were not approved by the voters at that time. Per the language of Section 12.08, the City Council needs to initiate the review of the Charter.

This item is on the Council Agenda to provide the opportunity for Council to discuss and determine how to proceed with the intent of finalizing the ballot language, if appropriate, no later than the February 12, 2026, City Council Meeting. If Council determines to go forward with the review, I will, as City Manager, prepare a report that addresses any existing conflicts with State law and such recommendations that are necessary for the City's legal, administrative or other reasons that change may be appropriate. Those changes will be in the form of ballot questions with the intent of completing the review and gaining Council approval no later than the February 12, 2026, Council meeting for inclusion on the May 2, 2026, ballot.

It should be noted that the Section 12.09 Charter Amendment provides for another opportunity as follows:

Section 12.09 Clerical Charter Amendments by Council

*The Council shall have the power, by ordinance, to renumber and rearrange all articles, sections, subsections, paragraphs and subparagraphs of this Charter or any amendments hereto, as the Council shall deem appropriate, including the power to correct typographical errors and to conform cross-references in the body of the text of this Charter, so long as no substantive change is made without complying with Section 12.08 of this Charter.*

Such a review has been initiated and will be coming to Council for consideration.

**Focus Area(s):** The City of Marshall is required to begin the Charter review, based on a report from the City Manager, for items / issues to discuss for consideration for inclusion as a possible amendment. How this review can be accomplished varies from city to city. Generally, it is composed of Councilmembers. In some cities where I have assisted with this process, each Council District appointed a representative to be part of the Review Committee, along with a representation of the City Council to gain input on the front end of the process. The composition of the Committee needs to be what the Council believes would work best. It is recommended that if a Committee with residents is determined to be the appropriate composition, then no more than eleven (11) total members be on the Committee. The larger the group, the more difficult it is to gain a quorum as well as facilitate the meetings.

In addition, as was included during the 2019 review, the use of an attorney who has experience in Charter review and amendments, processes and preparation of ballot language would be beneficial beginning with the first meeting of the Committee. They also may have knowledge of specific State law that is in conflict with the Marshall Charter.

**Budget Cost:** Funds are included in the Proposed FY26 Budget for an election in May 2026. Costs associated with the use of an attorney to help with this process are not specifically identified, but I believe funds can be made available. At this time, we didn't know if the Council would move in the direction of use of an Attorney for this purpose and how many hours would be required, which is partially based on the number of recommended amendments.

**Staff Contact:**

**Attachments:**       None